

Operator's Handbook

Monarch® 9906
Printer

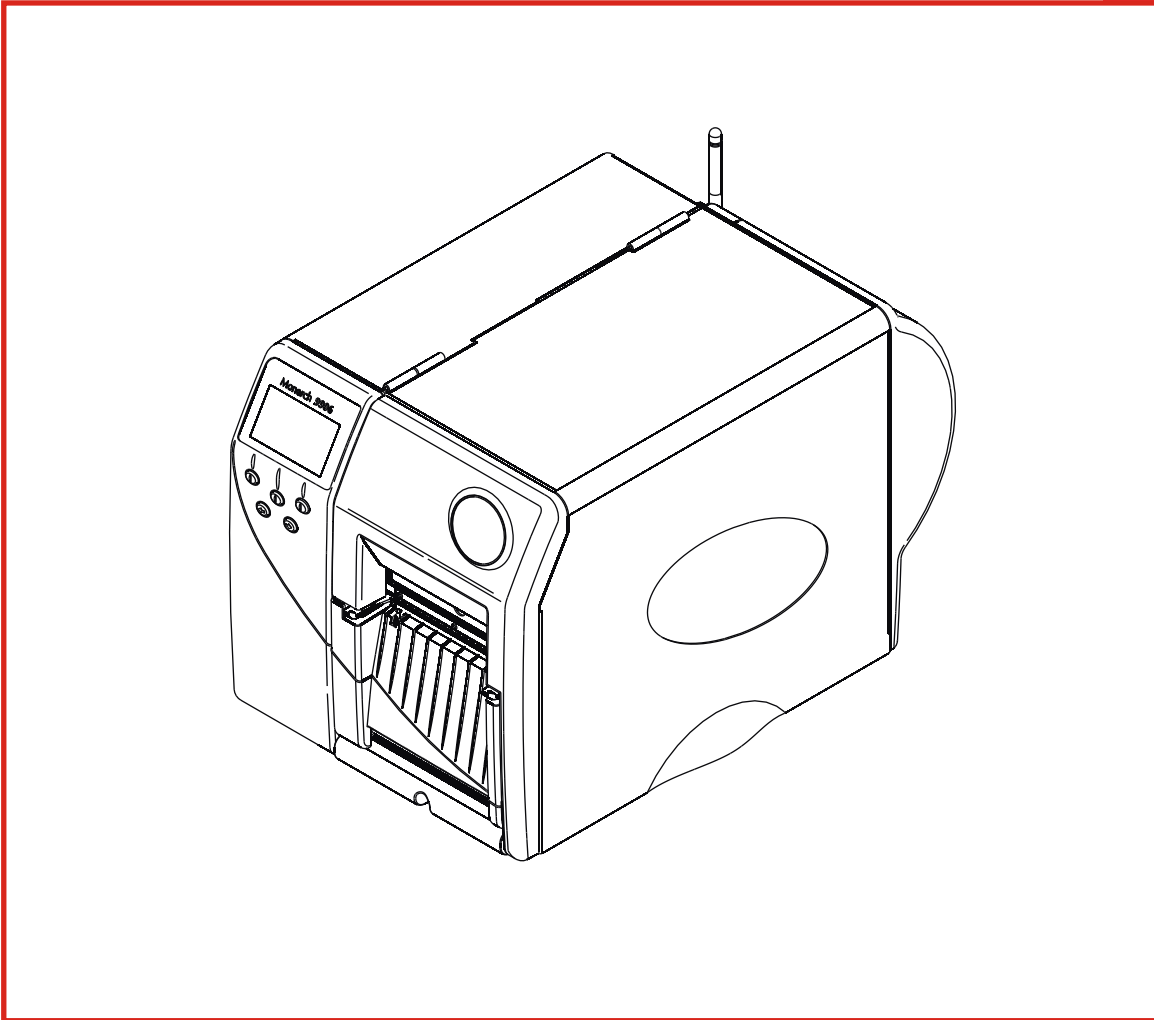

Each product and program carries a respective written warranty, the only warranty on which the customer can rely. Avery Dennison Corp. reserves the right to make changes in the product, the programs, and their availability at any time and without notice. Although Avery Dennison Corp. has made every effort to provide complete and accurate information in this manual, Avery Dennison Corp. shall not be liable for any omissions or inaccuracies. Any update will be incorporated in a later edition of this manual.

©2010 Avery Dennison Corp. All rights reserved. No part of this publication may be reproduced, transmitted, stored in a retrieval system, or translated into any language in any form by any means, without the prior written permission of Avery Dennison Corp.

WARNING

This equipment has been tested and found to comply with the limits for a Class A digital device, pursuant to Part 15 of the FCC Rules. These limits are designed to provide reasonable protection against harmful interference when the equipment is operated in a commercial environment. This equipment generates, uses, and can radiate radio frequency energy and, if not installed and used in accordance with the instruction manual, may cause harmful interference to radio communications. Operation of this equipment in a residential area is likely to cause harmful interference in which case the user will be required to correct the interference at their own expense.

CANADIAN D.O.C. WARNING

This digital apparatus does not exceed the Class A limits for radio noise emissions from digital apparatus set out in the Radio Interference Regulations of the Canadian Department of Communications.

Le présent appareil numérique n'émet pas de bruits radioélectriques dépassant les limites applicables aux appareils numériques de la classe A prescrites dans le Règlement sur le brouillage radioélectrique édicté par le ministère des Communications du Canada.

Trademarks

Monarch® and MPCL are trademarks of Avery Dennison Retail Information Services LLC.

Avery Dennison® is a trademark of Avery Dennison Corp.

TrueType is a registered trademark of Apple Computer, Inc.

Other products are trademarks or registered trademarks of their respective countries and are hereby acknowledged.

Avery Dennison
170 Monarch Lane
Miamisburg, OH 45342



TABLE OF CONTENTS

GETTING STARTED	1-1
Audience	1-2
Using this Manual	1-2
Ordering Programmer's Manuals.....	1-2
About Monarch® MPCL™ Toolbox Utilities	1-2
Connecting the Power Cable	1-3
Establishing Communications.....	1-3
Connecting the Communication Cable.....	1-3
Using the Control Panel.....	1-4
Power Save Mode.....	1-4
Selecting a Function	1-4
Exiting a Function	1-4
LOADING SUPPLIES	2-1
Loading Labels or Tags	2-2
Loading Labels for Optional Peel Mode.....	2-6
Using Optional Internal Liner Take-Up	2-8
Removing a Full Liner Take-Up Roll	2-9
Using the Optional Tear Bar.....	2-10
Adjusting the Printhead Pressure Dials	2-11
LOADING RIBBON	3-1
Loading Ribbon	3-2
SETTING SUPPLY OPTIONS	4-1
Setting the Supply Type	4-2
Setting the Ribbon	4-3
Using a High Energy Ribbon	4-4
High Energy Ribbon Limitations	4-4
Setting the Speed	4-5
Setting the Feed Mode	4-6
Setting the Backfeed	4-7
Changing the Position Settings	4-8
Setting the Print Position.....	4-8
Setting the Supply Position.....	4-9
Setting the Margin Position.....	4-10
Setting the Dispense Position	4-11
Setting the Backfeed Distance	4-12

Using Batch Separators	4-13
Using Skip Index.....	4-14
Using Rotate Image	4-15
Setting the Print Contrast	4-16
SETTING COMMUNICATIONS	5-1
Setting the Baud Rate	5-2
Setting the Word Length	5-3
Setting the Stop Bits	5-4
Setting the Parity.....	5-5
Setting the Flow Control	5-6
Resetting to Default Values	5-7
SETTING DEFAULTS	6-1
Setting the Monetary Sign.....	6-2
Setting the Secondary Sign.....	6-3
Setting the Number of Decimal Places	6-4
Setting the Slashed Zero Appearance	6-5
Setting the Power-Up Mode	6-6
Changing the Prompt Set.....	6-7
Setting the Numeric Format	6-8
Examples.....	6-8
Using Flash Storage.....	6-9
Using Flash Memory.....	6-10
Formatting Flash Memory	6-10
Checking Available Flash Memory	6-11
Packing Flash Memory	6-12
Setting the Image Error Mode	6-13
Setting the Configuration Packet Mode	6-14
Setting the Error Retry Mode.....	6-15
Memory Guidelines	6-16
USING SCRIPTS	7-1
Initial Script Startup Procedures.....	7-1
Viewing Script Information	7-2
Downloading a Script	7-3
Enabling a Script	7-4
Deleting a Script.....	7-5
Enabling Status Polling	7-5
Enabling Status Polling	7-6
Using Immediate Commands	7-7

SETTING RFID OPTIONS	8-1
Using RFID Supplies	8-2
Using the RFID Setup Menu	8-2
Read Tag.....	8-2
RF Power (Read/Write Value)	8-3
Clear Data	8-4
Printing a Configuration Label.....	8-4
Setting the Error Action	8-5
PRINTING	9-1
Printing.....	9-1
Printing a Test Label.....	9-2
On-Demand Mode Printing.....	9-2
Pausing a Batch	9-3
Restarting a Batch	9-3
Canceling a Paused Batch	9-3
Canceling a All Batches.....	9-4
Repeating a Batch	9-4
Printing TrueType® Fonts	9-5
Licensing Your Fonts	9-5
CARE & MAINTENANCE	10-1
Clearing Label Jams	10-1
Cleaning	10-2
Replacing the Printhead	10-4
DIAGNOSTICS & TROUBLESHOOTING	11-1
Factory Set Password	11-1
Checking the Software Version.....	11-2
Checking Supply Quality.....	11-3
Using Password Protection	11-4
Enabling the Password (System Administrators only)	11-4
Service Diagnostics	11-4
Troubleshooting.....	11-5
Error Messages	11-6
Common Errors	11-6
SPECIFCATIONS	A-1
Printer	A-1
Supplies	A-2
Ribbon Specification	A-2
About Ribbons.....	A-2

Cable Pinouts.....	A-3
ACCESSORIES & OPTIONS.....	B-2
Accessories	B-2
Packaging Materials.....	B-2
Shipping the Printer	B-2
Factory-Installed Options.....	B-2
GLOSSARY	G-1
INDEX.....	I-1

GETTING STARTED

The Monarch® 9906 printer prints text, graphics, and bar codes on thermal transfer (ribbon) and thermal direct labels or tags. The printer prints labels continuously (in one strip) or on-demand (one label at a time).

You can print on inside edge aperture, die cut, black mark, or continuous (non-indexed) supplies. Continuous supply must be used in continuous mode. See "[Supply Type](#)" in Chapter 4 for more information about the supply types.

This chapter includes information about:

- ◆ connecting the power cord.
- ◆ connecting the communication cable.
- ◆ using the printer's control panel.

Several chapters of this manual have one or more charts showing the printer's menu structure. For example:

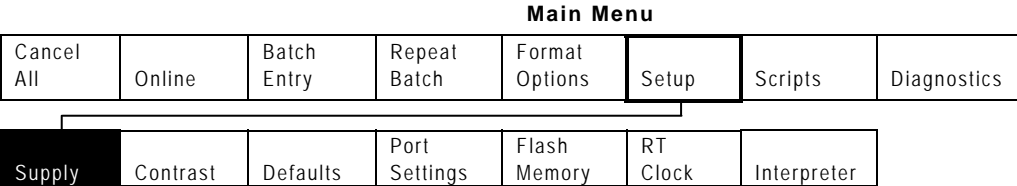

The solid black box shows where you are; the bordered box and path show how you got there.

The printer is packaged with a power cord and a ribbon take-up core (may already be on take-up reel). Keep the box and packaging material in case the printer ever needs repair.

Audience

The *Operator's Handbook* is for the person who prints and applies labels.

Using this Manual

Manual content summary:

Chapter		Contents
1	Getting Started	Contains information about connecting the power cable and using the control panel.
2	Loading Supplies	Describes how to load a roll of supply, fan-fold supply, and tag supply.
3	Loading Ribbon	Describes how to load a roll of ribbon.
4	Setting Supply Options	Using the Supply menu to set the various supply options (supply, ribbon, feed mode, etc.).
5	Setting Communication Values	Using the Port Settings menu to set the serial and parallel communication values (baud rate, parity, etc.).
6	Setting Defaults	Using the Defaults menu to set the monetary sign, number of decimal places, prompt set, etc.
7	Using Scripts	Using the Scripts menu to load a script, enable a script, delete a script, etc.
8	Printing	Explains how to print labels and use the Pause menu.
9	Care & Maintenance	Describes how to clear a label jam, clean the printer, and replace the printhead.
10	Diagnostics & Troubleshooting	Describes how to print a test label and lists common problems and their solutions.
A	Specifications	Contains printer and supply specifications.
B	Accessories & Options	Contains printer accessories and optional equipment.

Ordering Programmer's Manuals

The *9906 Packet Reference Manual* can be downloaded from our Web site. It describes how to create format and batch packets for printing labels, how to configure the printer online, how to diagnose printer error messages, and how to perform other advanced techniques.

About Monarch® MPCL™ Toolbox Utilities

The Monarch® MPCL™ Toolbox utilities are available on our Web site and are free to download. This group of development utilities helps you configure the printer, customize fonts, and download files. Monarch MPCL Toolbox utilities are not label production software. Call Customer Service for information about label production software.

Connecting the Power Cable

The power supply automatically switches between 115V or 230V. Operator settings are not required.

1. Plug the power cable into the connection located at the back of the printer. Plug the other end of the cable into a grounded electrical outlet.

Note: Only use a certified power cable with proper voltage for the country of installation.

2. Turn on the printer. Press (I) to turn on and (O) to turn off the printer.

Establishing Communications

Before the printer can accept print jobs from the host, you must:

- ◆ connect the communication cable to the printer (make sure printer is turned off) and to the host.
- ◆ set the communication values on the printer to match those at the host (only required if you are using the serial port).

Ask your System Administrator which method to use for communication with the host:

Serial Communication 9 to 9-pin cable
(Part #126716)

Host USB, Device USB

Parallel Communication (optional)

Ethernet (optional)

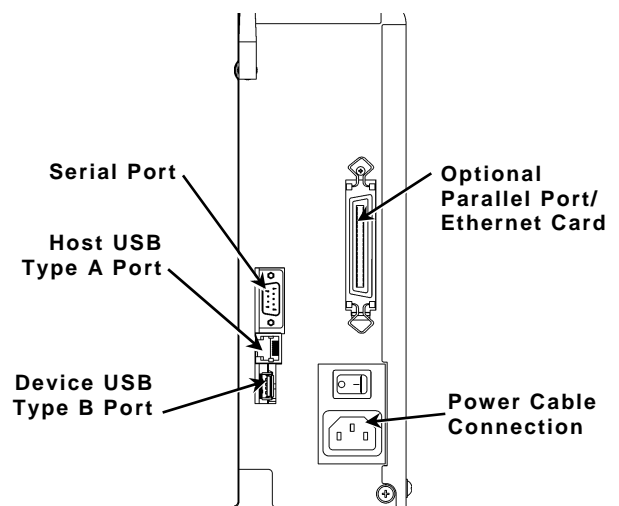

Connecting the Communication Cable

Connect the communication cable into the appropriate port. Secure the cable with the connecting screws (serial) or spring clips (parallel).

If you are communicating with the host through the serial port, make sure the printer's communication values match those at the host. The printer's default values are 9600 Baud, 8 bit data frame, 1 stop bit, no parity, and DTR flow control.

Using the Control Panel

The control panel consists of a four-line LCD display and five buttons. The top three buttons are function buttons. The function of each button varies depending on the task. Each button's function is shown on the display above the button. The two bottom buttons are navigation buttons. Use these buttons to scroll through menus.

The LCD display:

- ◆ indicates power when text or other information is shown.
- ◆ indicates conditions requiring immediate attention (low battery, faults, errors) using a red background.
- ◆ shows menu prompts, printer settings, function button assignments, values, etc.

For more information see Chapter 10, "[Diagnostics & Troubleshooting](#)."

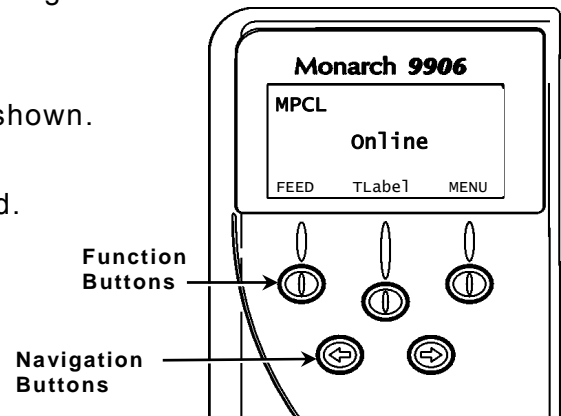

Power Save Mode

When the printer is idle for longer than 55 minutes, it goes into power save mode, turning off the display's back light and all motors. The printer wakes from power save mode when it receives a format or any button is pressed (printer performs the button's action).

Selecting a Function

The Main Menu has several functions (operating modes). These functions are shown in the chart below.

Main Menu							
Cancel All	Online	Batch Entry	Repeat Batch	Format Options	Setup	Scripts	Diagnostics
Supply	Contrast	Defaults	Port Settings	Flash Memory	RT Clock	Interpreter	

- ◆ To display menu options, press ← or →.
- ◆ Press **SELECT** when you see the menu option you need.

The Main Menu controls the printer's setup and operation. Through the Setup Menu, you can select a sub-menu for the supply, contrast, default, port settings, flash memory, or real-time (RT) clock. Each of the sub-menus has several options, such as ribbon, speed, monetary symbols, and baud rate.

Exiting a Function

There are two ways to exit an option. Pressing **BACK** once exits to the previous menu and saves any changes. Pressing **CANCEL** exits to the previous menu; however, changes are not saved.

LOADING SUPPLIES

This chapter describes how to load:

- ◆ a roll of supply
- ◆ fan-fold supply
- ◆ a roll of tag supply.

There are two types of supplies:

Thermal Direct specially treated thermal supplies that do not use a ribbon for printing

Thermal Transfer standard supplies that require a ribbon for printing

If you are using thermal direct supplies, do not load a ribbon.

If you switch from black mark to die cut supplies, make sure the printer's supply type is set correctly. See "[Supply Type](#)" in Chapter 4 for more information. Your System Administrator can also send the supply setup packet to change the supply type. Refer to the optional *9906 Packet Reference Manual* for more information about sending the supply setup packet.

Loading Labels or Tags

1. Open the cover.
2. Unlock the printhead by turning the retaining latch.

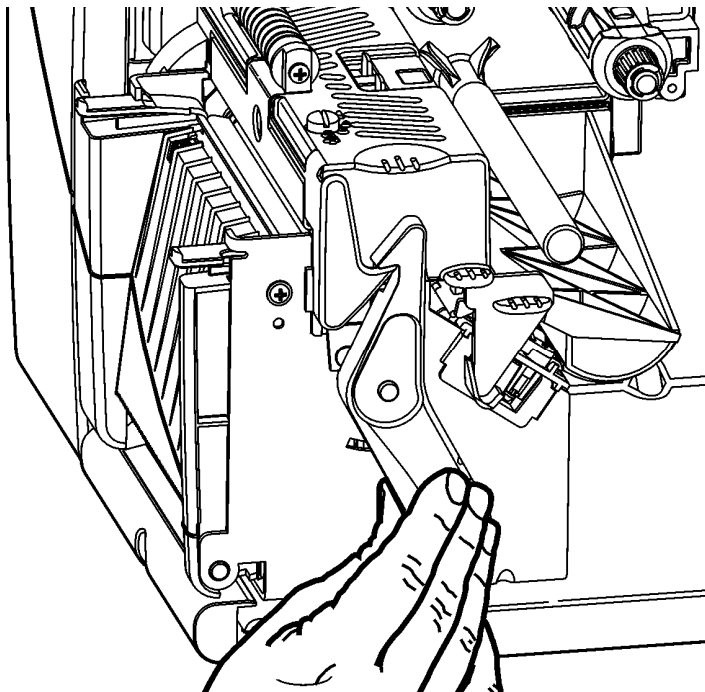

3. Lift the printhead assembly using the printhead tab until the assembly locks into place.

Note: User “touch parts” are yellow.

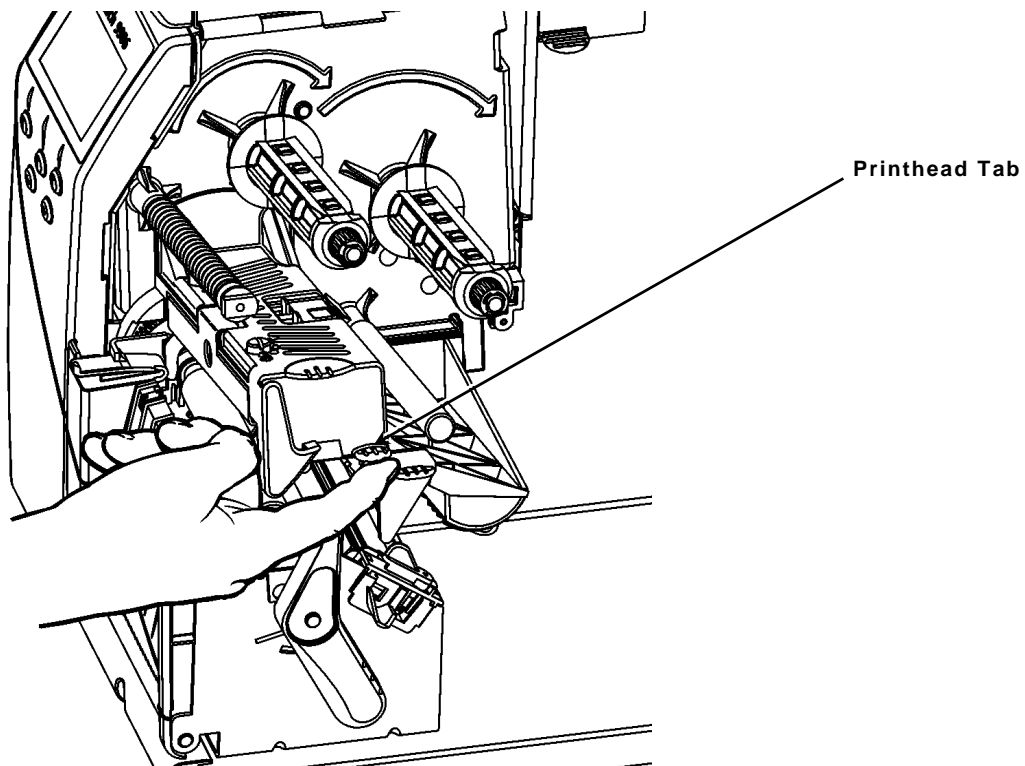

4. Place rolled supply on the supply holder, located against the inside of the printer. Rolled label supply unrolls from the top or the bottom; rolled tag supply unrolls from the bottom only (tag rolls are wound face in).

Note: Do not pick the printer up by the supply holder.

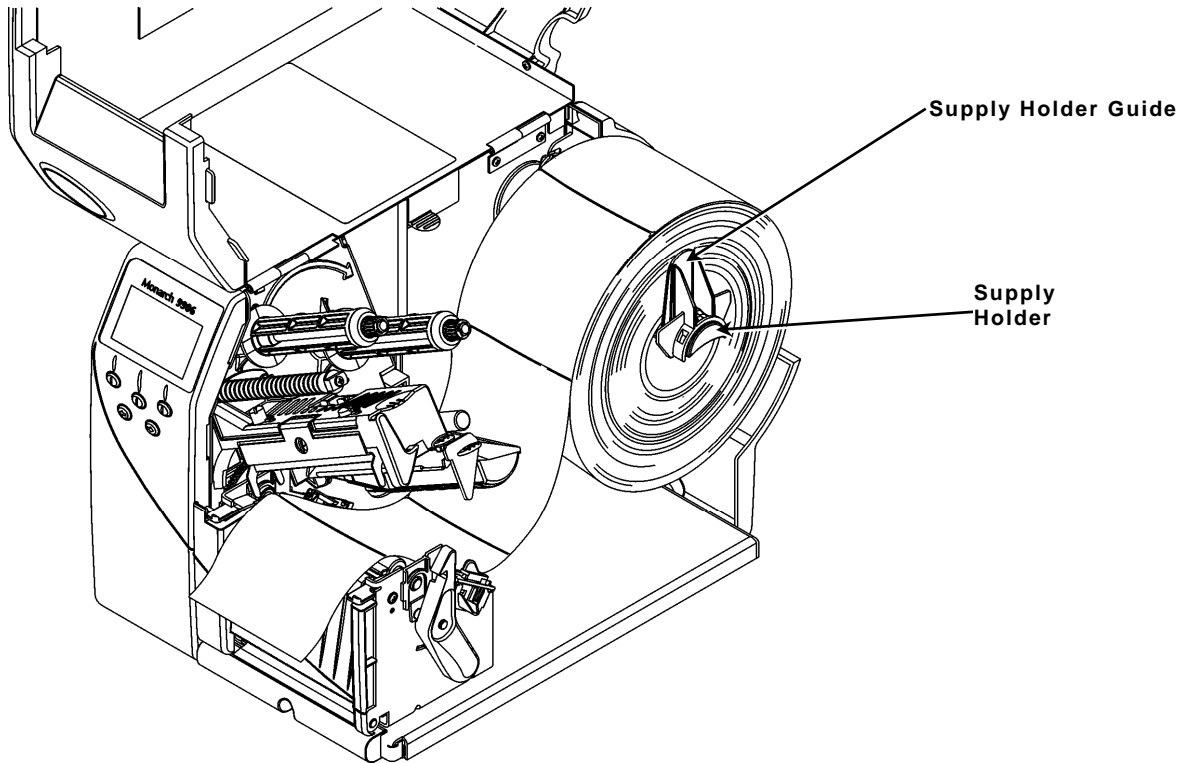

Place a fan-fold supply stack behind the printer, label side facing up. Lay the label strip over the supply holder.

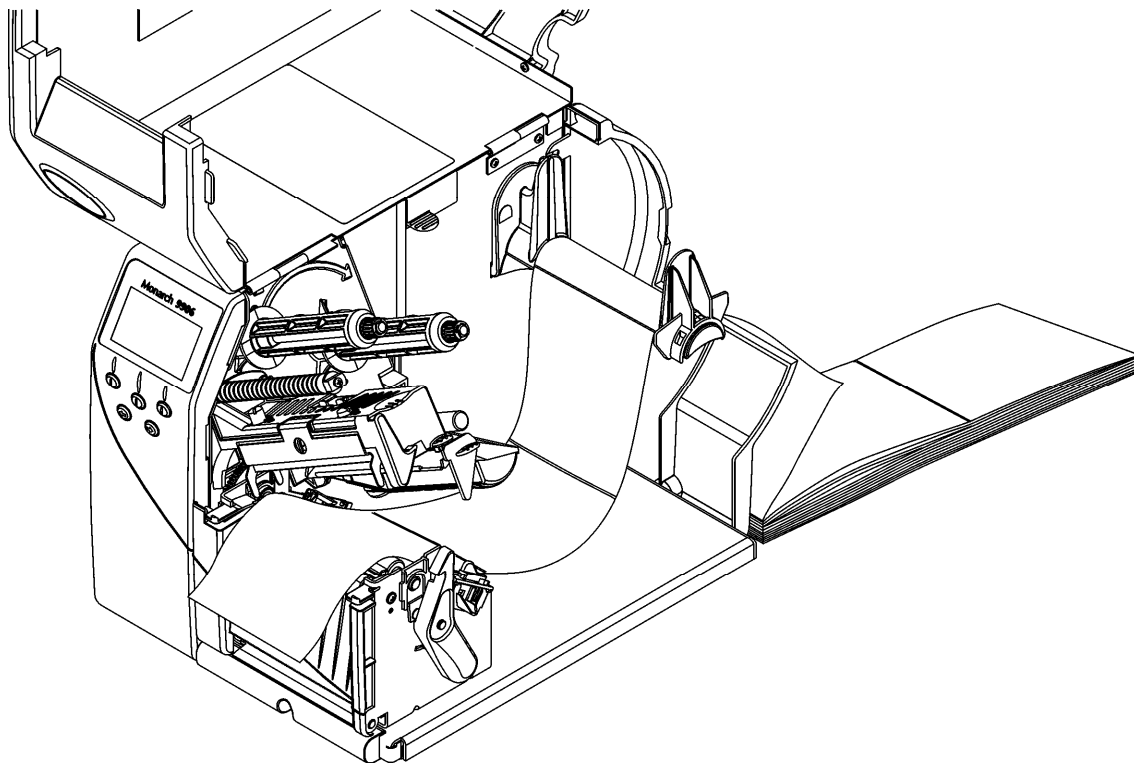

5. Adjust the supply holder guide so that it barely touches the supply, making sure the supply moves freely.

6. Push down on the supply lever to unlock the supply guides.
7. Lay the label strip across the supply guide so that a few inches extend past the front of the printer. Tuck the supply under the nibs and supply sensor. **Do not feed supply between the supply roller and deflector.**

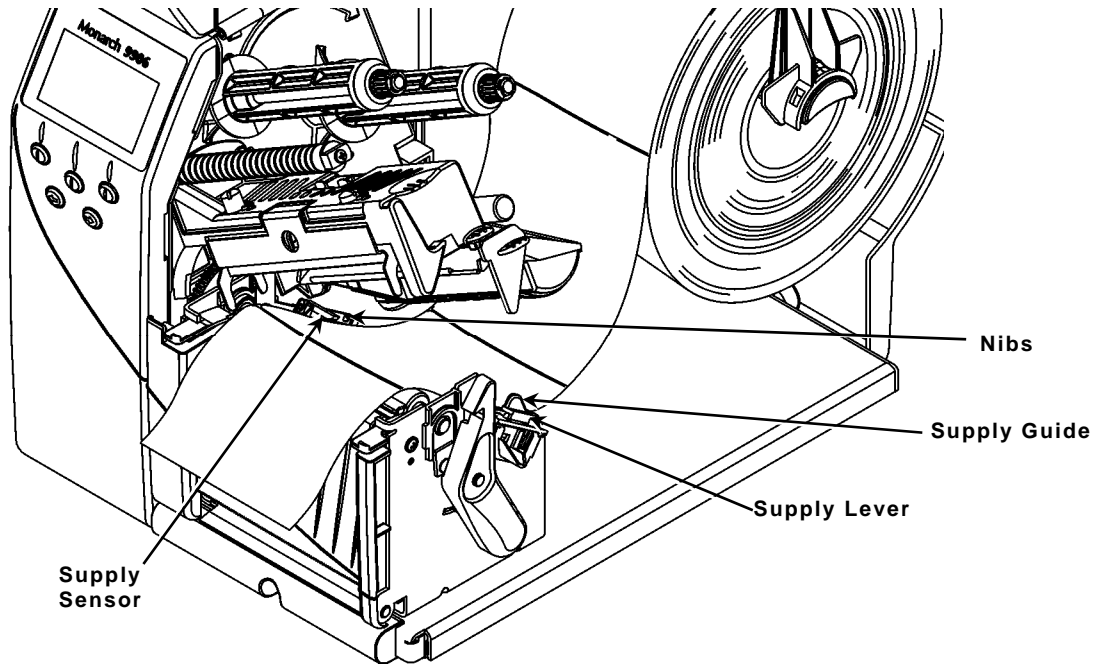

8. Adjust the supply guide so it barely touches the supply. Push up on the supply lever to lock the supply guide into place.
9. Hold the printhead assembly by the printhead tab while pushing the printhead release.

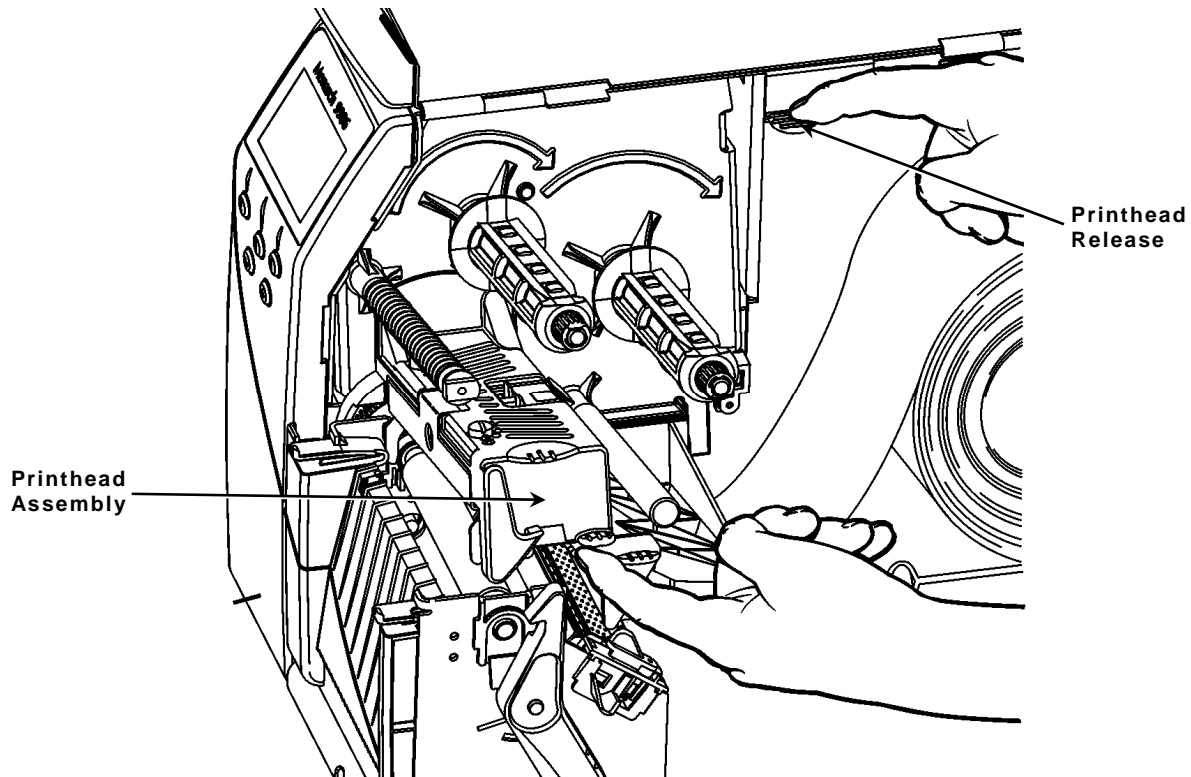

10. Close the printhead by pressing down on the thumb well until you hear it click into place.

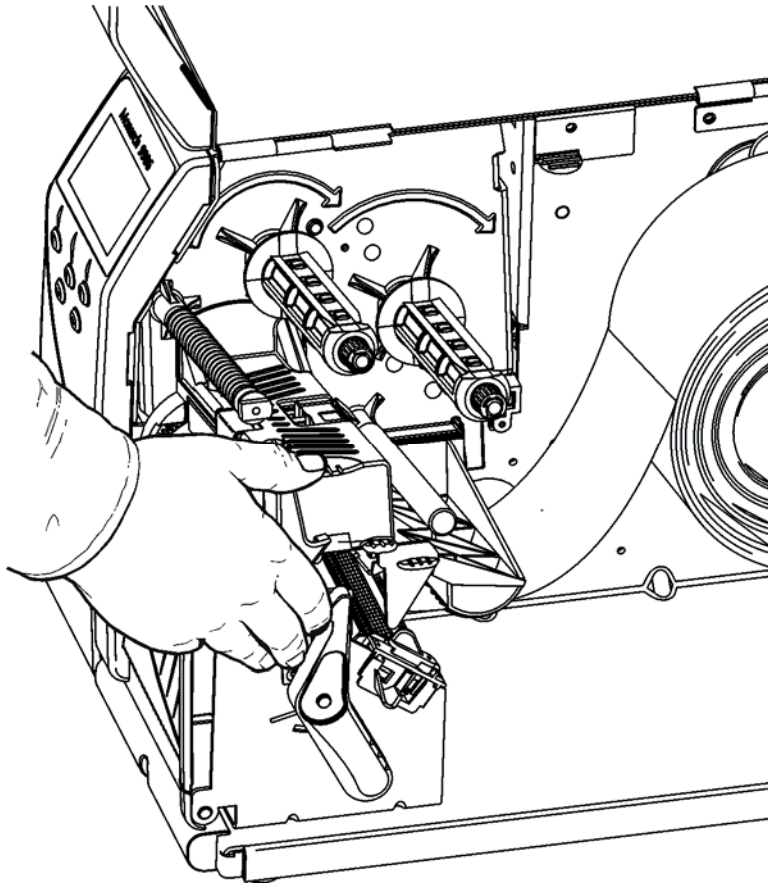

11. Close the printer's cover.

12. Press **FEED** to position the supply under the printhead.

You may need to adjust the printhead pressure dials depending on the width of your supply. See "[Adjusting the Printhead Pressure Dials](#)" for more information.

Note: If the printer will be unused for extended periods of time, we recommend leaving the printhead unlatched.

Loading Labels for Optional Peel Mode

Peel mode is optional and must be purchased separately. In peel mode, the printer separates the liner from the label. The next label is not printed until the completed one is removed from the printer. Make sure the printer is configured for on-demand mode and the correct supply type.

The minimum feed length is 1.5 inches for peel mode. We recommend using 0.5-inch gap supplies in peel mode when backfeed is disabled. Hold the leading edge of peeled labels when printing on stock longer than six inches. You must use non-perforated supplies for peel mode.

Follow the steps for loading supplies from the previous section, close the printhead, and follow these steps.

1. Remove the labels from the first 10 inches of the liner.
2. Press down on the exit cover tabs to open the exit cover on the front of the printer.

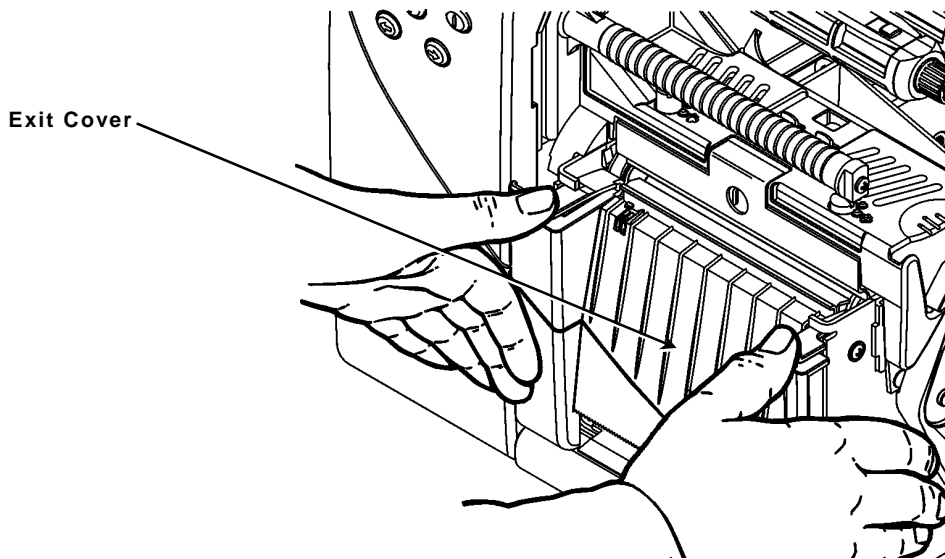

3. Feed the liner over the peel roller, along the chute, and out through the lower opening in the exit cover.

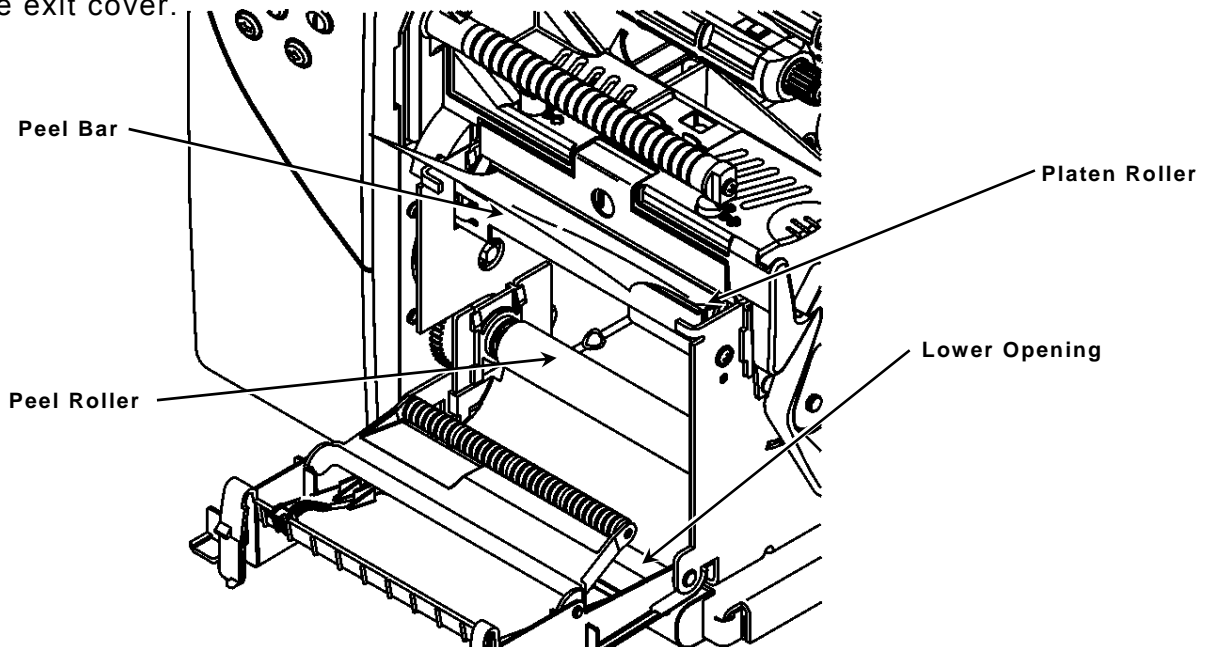

4. Close the exit cover.

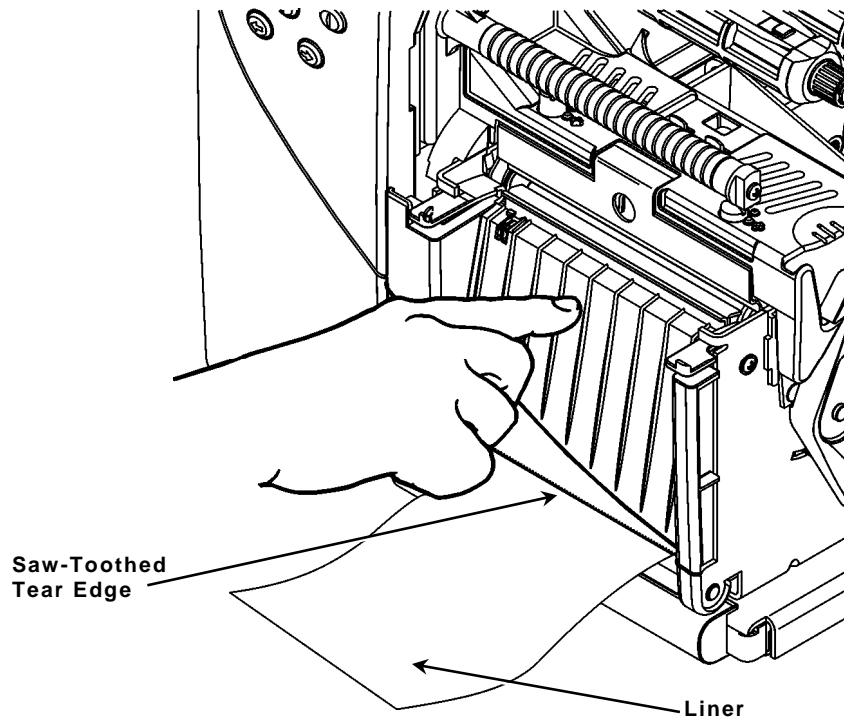

5. Close the printer's cover.

6. Press **FEED** to position the supply under the printhead.

Note: When removing the liner, pull up across the saw-toothed tear edge.

Using Optional Internal Liner Take-Up

Internal liner take-up must be used with peel mode. This feature collects the liner on a take-up reel located inside the printer's cover. See "Setting the Feed Mode" for instructions to set the printer for Internal Liner Take-Up.

Follow the steps for loading supplies for peel mode and then follow these steps.

1. Press down on the exit cover tabs to open the exit cover on the front of the printer.
2. Remove the labels from the first 18 inches of the liner.
3. Position the liner take-up reel so the open notch is facing up.
4. Position the liner take-up core so the open slot is facing up. Line up the slot in the core with the notch in the reel. Slide the empty liner take-up core on the liner take-up reel.

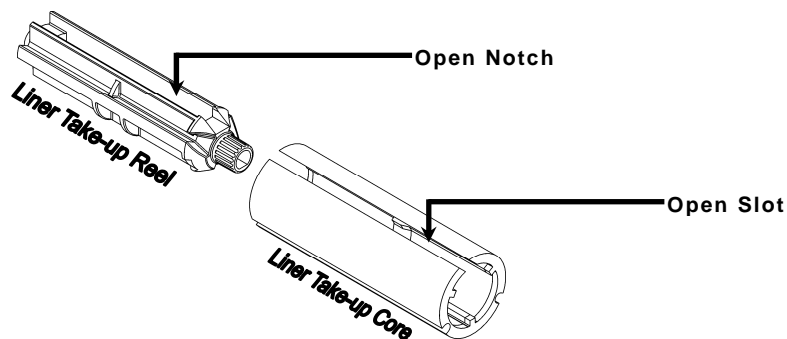

5. Feed the liner over the peel bar, under the peel roller, under the liner take-up core and around in a counter-clockwise direction.
6. Place the end of the liner in the take-up core's opening.

Note: Fold the edge of the liner to easily insert it in the core's open slot.

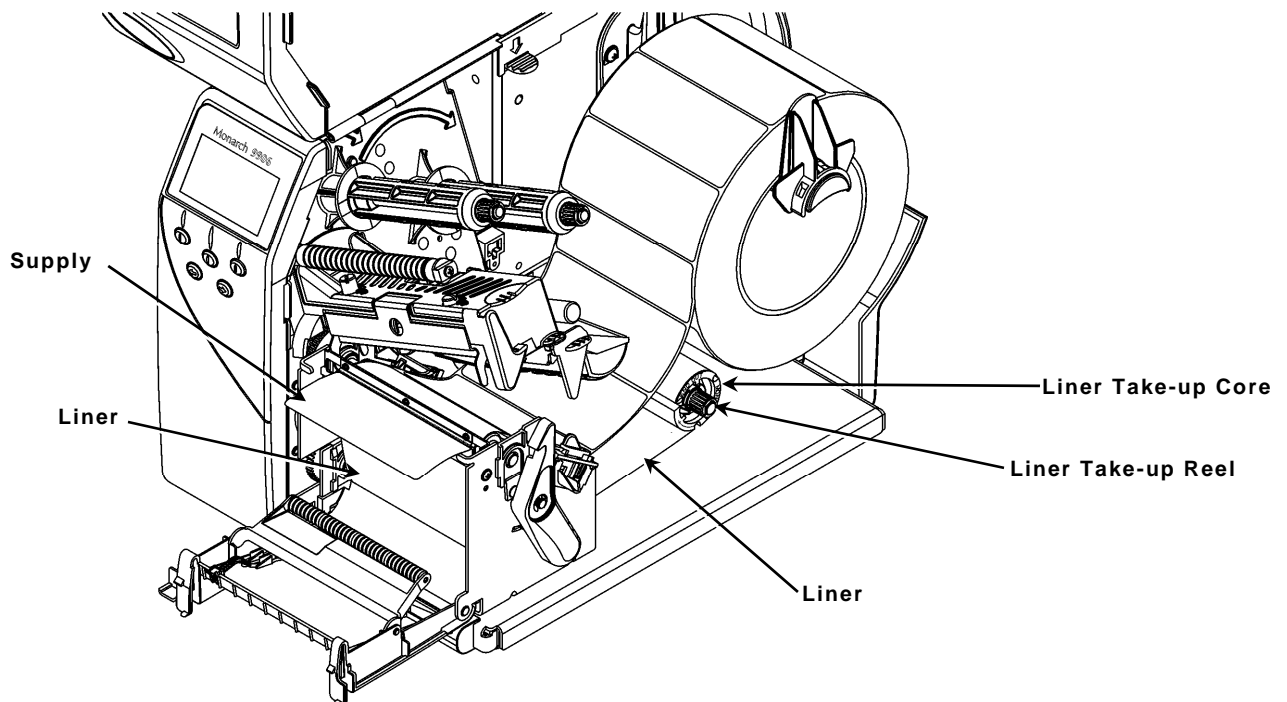

7. Hold the liner in place while turning the take-up reel in a counter-clockwise direction to remove slack in the supply liner.
8. Close the printhead assembly until you hear it click in to place.
9. Close the printer's cover.
10. Close the exit cover.
11. Press **FEED** to position the supply under the printhead.

Removing a Full Liner Take-Up Roll

Remove the liner take-up when the printer alerts you to a full roll. The liner take-up reel holds half of a roll of supply. See "[Common Errors](#)" in Chapter 10 for more information.

1. Open the cover.
2. Unlock the printhead assembly by turning the retaining latch.
3. Press down on the exit cover tabs to open the exit cover on the front of the printer.
4. Use scissors to cut the liner in front of the take-up reel.

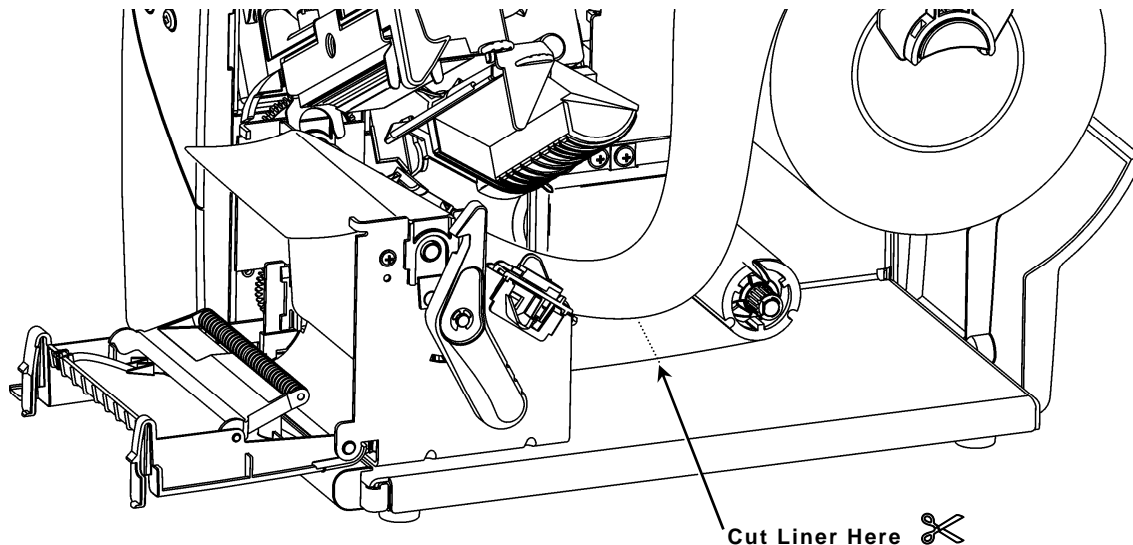

5. Gently pull the full liner take-up core off the reel.

Note: Place your fingers between the take-up core and printer wall. Gently push the core off the reel. This eases removal and minimizes the liner telescoping from the reel.

6. Remove the liner from the take-up core.
7. Reload supply and continue printing.

Using the Optional Tear Bar

The tear bar is optional and must be purchased separately. It can only be used with peel mode.

Slide the supply between the tear bar and peel bar. It may be easier if you cut or fold one corner of the supply first.

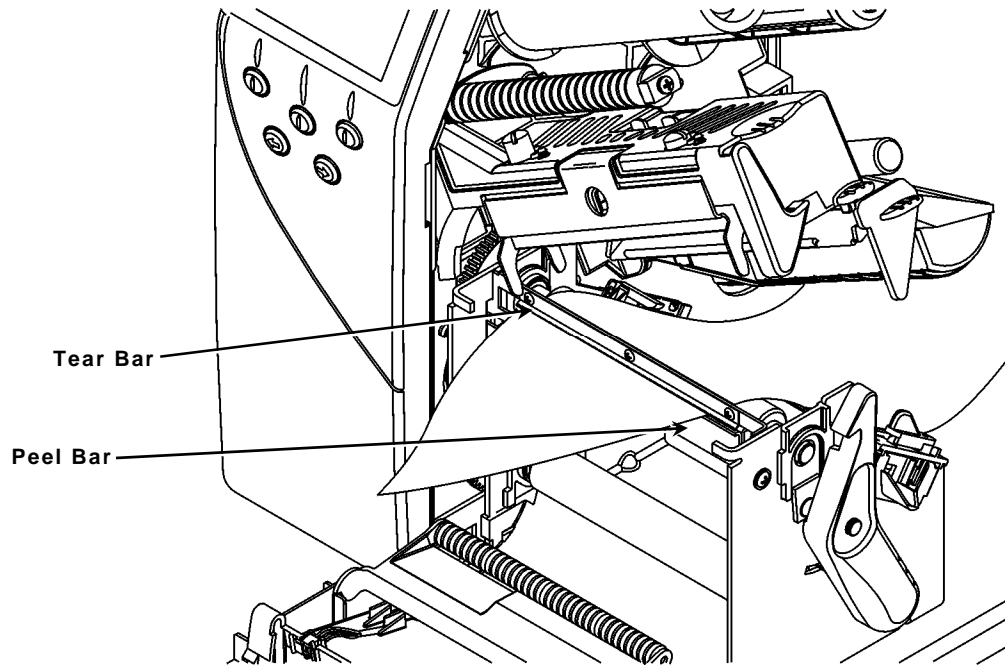

Notes:

- ◆ The tear bar can only be used when supply is loaded for peel mode. Do not tear both label and liner at the same time.
- ◆ Tear labels against the tear bar.
- ◆ Tags can not be used with the tear bar.
- ◆ For ease of tearing, use 3-inch long by 1-inch wide supplies that are less than 5 mils thick.

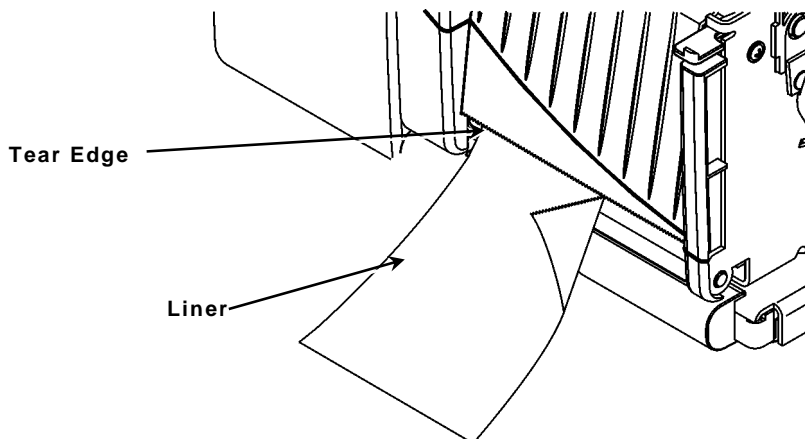

Adjusting the Printhead Pressure Dials

The default setting is least pressure, which provides optimal printing in most cases. If you see smudging, ribbon wrinkling, or poor print quality, you may need to adjust the printhead pressure dials.

The two dials are located on either edge of the printhead assembly (inside and outside). The dials may be set to different positions; however, the inside dial should be equal to or more pressure than the outside dial. Use a coin or flathead screwdriver to adjust the dials.

Each dial has four settings:

- ◆ Least pressure
- ◆ Light pressure
- ◆ Medium pressure
- ◆ Most pressure

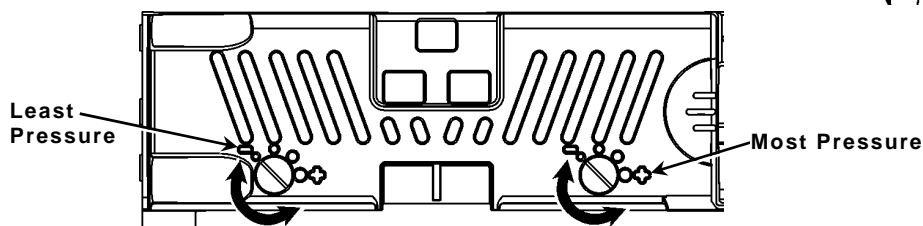
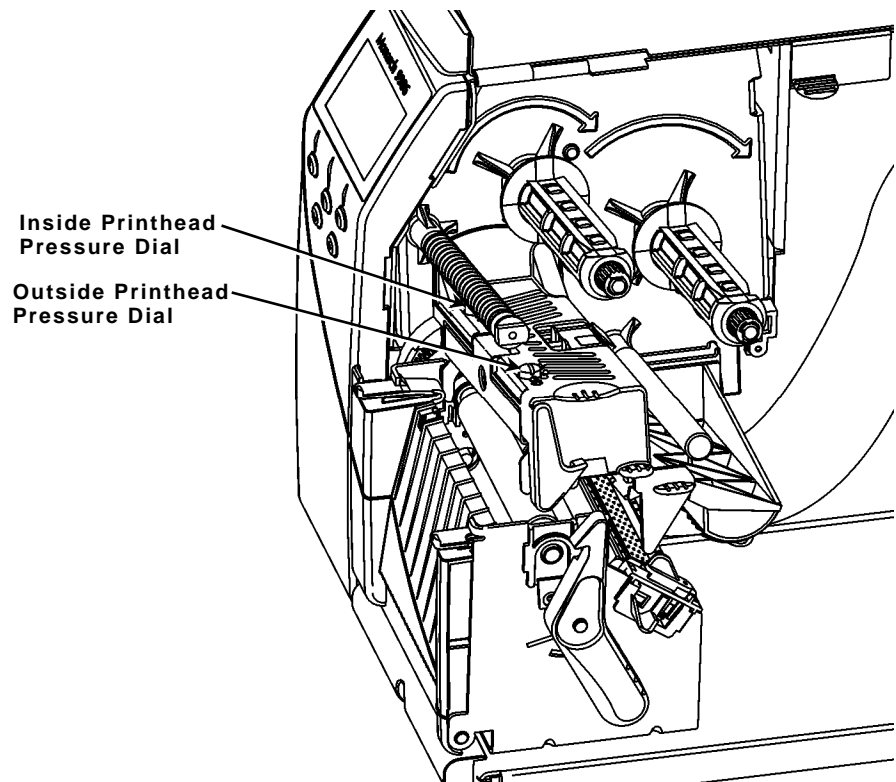

Use the following guidelines to adjust printhead pressure.

Supply/Ribbon	Dial Settings
Wide supply (> 2 inches)	Increase both dials one step, check print quality, repeat if necessary.
Narrow supply (\leq 2 inches)	Increase inside dial one step, check print quality, repeat if necessary. If uneven printing occurs you may need to increase the outside dial.
TUFF-MARK® wide (> 2 inches)	Increase both dials to the most pressure setting.
TUFF-MARK® narrow (\leq 2 inches)	Increase the inside dial to most pressure and the outside dial to light pressure.

Print a test label to check the printhead pressure; make adjustments as necessary.

LOADING RIBBON

This chapter describes how to load a ribbon roll.

There are different ribbon requirements for the two types of supplies:

Thermal Direct Supplies does not use a ribbon for printing

Thermal Transfer Supplies requires a ribbon for printing

If you are using thermal direct supplies, do not load a ribbon.

Note: User “touch parts” are yellow.

Loading Ribbon

Make sure the printer is configured to use a ribbon.

To load ribbon:

1. Open the cover.
2. Unlock the printhead by turning the retaining latch.
3. Lift the printhead assembly using the printhead tab until the assembly locks into place.
4. Push the deflector tab down.

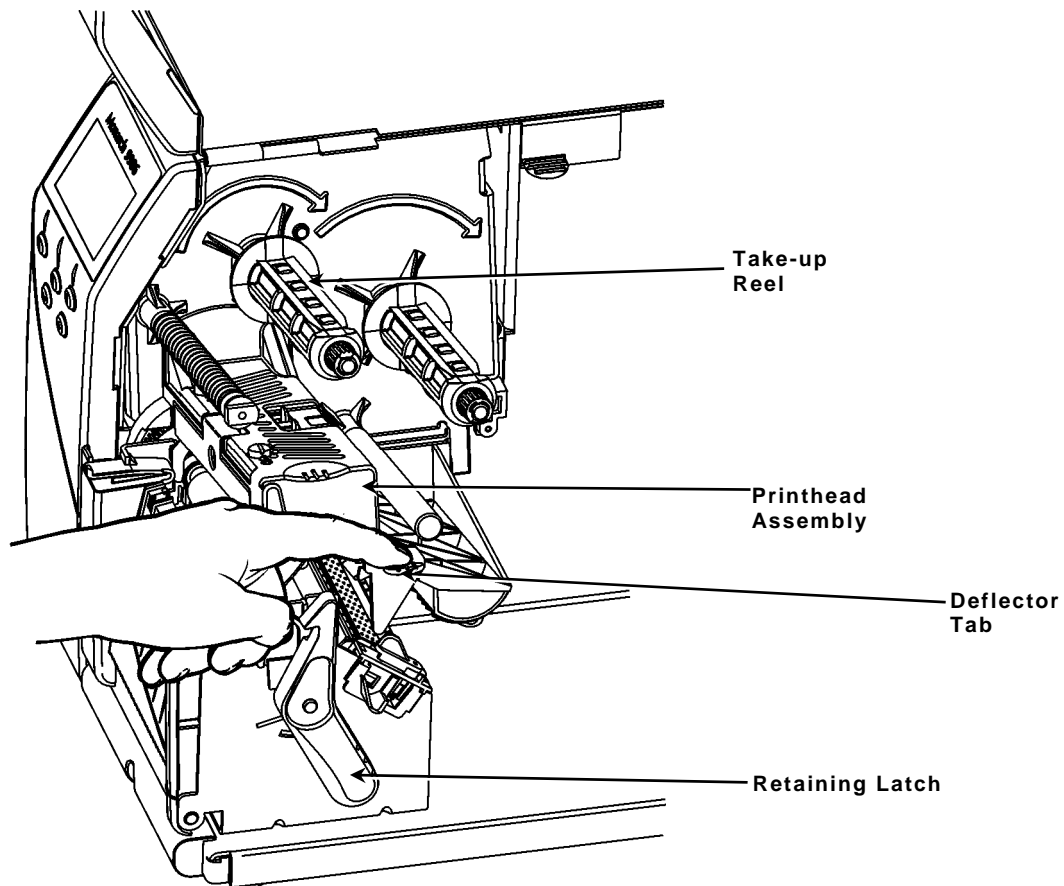

5. Slide an empty ribbon core on the take-up reel as far as it will go.
6. Remove the new ribbon from the package. Do not wrinkle or crush the ribbon.

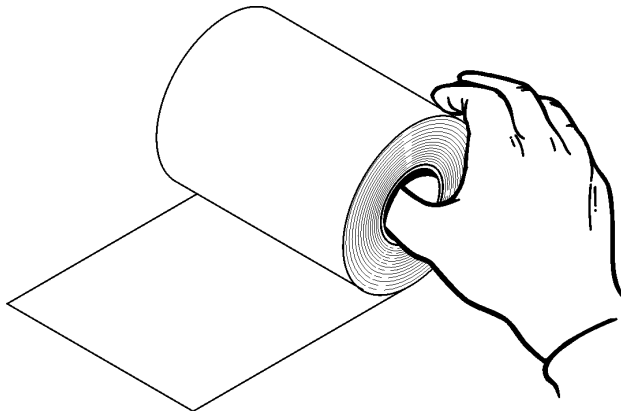

7. Position the ribbon so that it unwinds in a clockwise direction. Slide the ribbon onto the back reel as far as it will go. Carefully unwind a few inches of ribbon from the bottom of the roll.

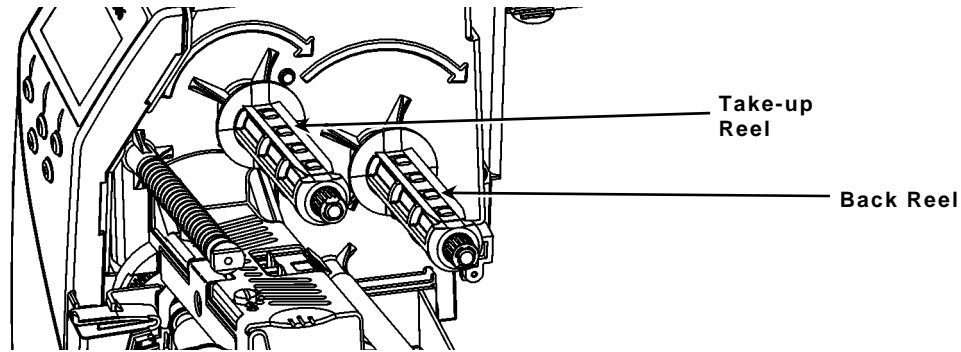

8. Carefully feed the ribbon under both ribbon rollers and printhead.
9. Align the ribbon and make sure it is straight and centered throughout the path.

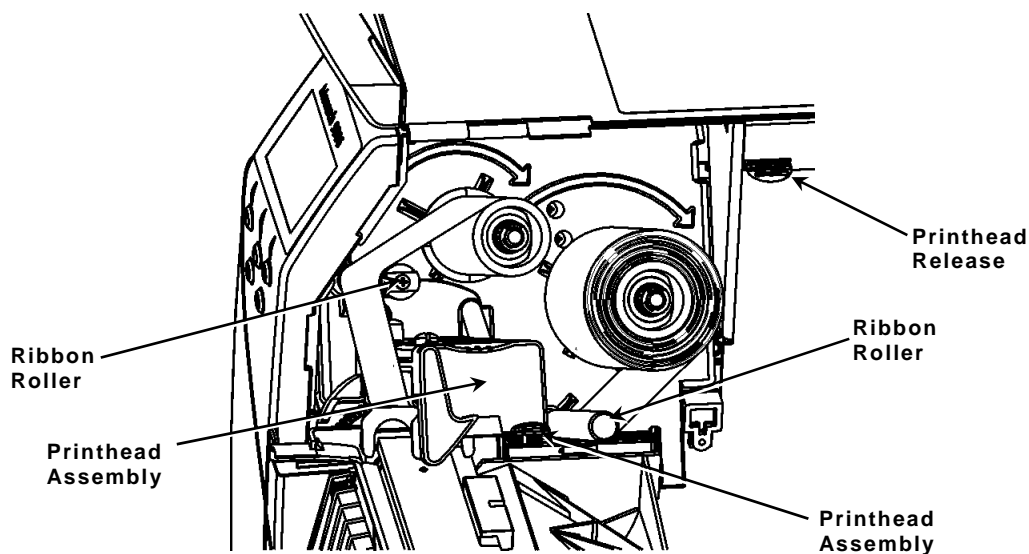

10. Tape the ribbon to the take-up core. ***Do not tape the ribbon to the take-up reel.***
11. Rotate the take-up core until the leader is past the printhead.
12. Remove any slack in the ribbon by turning the take-up reel clockwise.
13. Hold the printhead assembly by the printhead tab while pushing the printhead release.
14. Close the printhead by pressing down on the thumb well until you hear it click into place.
15. Close the printer's cover.

SETTING SUPPLY OPTIONS

This chapter explains how to select the supply type, ribbon, speed, feed mode, backfeed, print position, supply position, margin position, cut position, dispense position, backfeed distance, separators, skip index mode, rotate image, and print contrast.

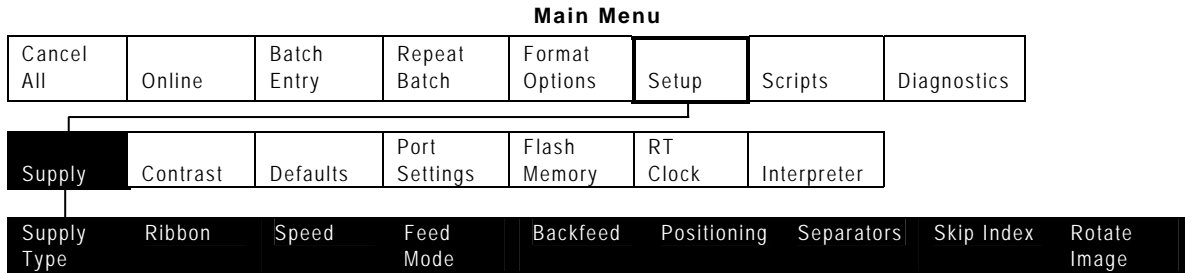

Your System Administrator may limit access to this menu to prevent changes. You are prompted to enter a password if password protection is turned on. To continue, ask your System Administrator for the password.

PASSWORD

ENTER BACK

The supply options are listed in the table below.

Option	Choices	Default
Supply Type	Aperture/Die Cut/Black Mark/Continuous	Die Cut
Ribbon	No/Yes/High Energy	Yes
Speed	2.5/4.0/6.0/Default	Default
Feed Mode	Continuous/On-Demand/Liner take-up	Continuous
Backfeed	Off/On	Off
Print Position	-450 to +450	0
Supply Position	-300 to 300	0
Margin Position	-99 to 99	0
Dispense Position	50 to 200	65
Backfeed Distance	10 to 100	65
Separators	No/Yes/Long	No
Skip Index	No/Yes	No
Rotate Image	No/Yes	No

To exit an option without changing the setting, press **CANCEL**.

Setting the Supply Type

You can print on inside edge aperture, black mark, die cut, or continuous supplies. You have to tell the printer which supplies you are using. To access this setting, from the Main Menu, select Setup, Supply, then follow these steps.

1. Press **←** or **→** until you see Supply Type.

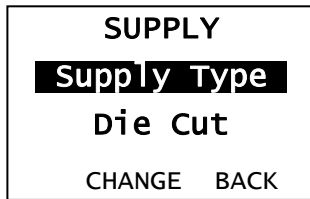

2. Press **CHANGE** to highlight the supply type options. The current setting is shown.
3. Press **←** or **→** to scroll through the supply type options.

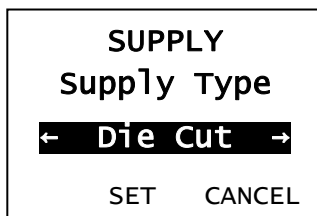

4. When you see the supply type you need, press **SET** to save the change. Press **CANCEL** to leave the supply type unchanged.
5. Press **BACK** until you return to the Home/Online screen.

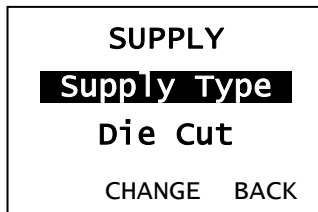

Setting the Ribbon

If you are using thermal direct supplies, do not load a ribbon and set the ribbon option to **No**. If you are using thermal transfer supplies, load a ribbon and set the ribbon option to **Yes**. If you are using high energy supplies (TUFF-MARK®), load a high energy ribbon and set the ribbon option to **High Energy**. See "[Using a High Energy Ribbon](#)" for more information.

To change the setting, from the Main Menu, select Setup, then Supply. Then, follow these steps.

1. Press **←** or **→** until you see Ribbon.

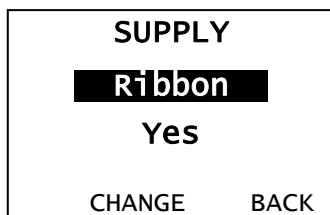

2. Press **CHANGE** to highlight the ribbon options. The current setting is shown.
3. Press **←** or **→** to scroll through the ribbon options.

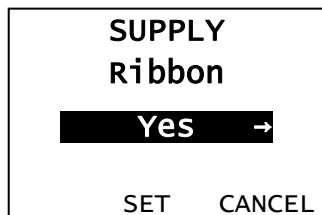

4. When you see the ribbon option you need, press **SET** to save the change. Press **CANCEL** to leave the ribbon option unchanged.
5. Press **BACK** until you return to the Home/Online screen.

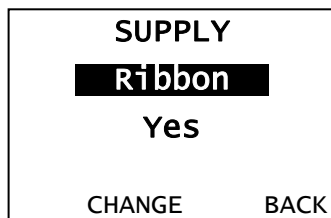

Note: If you choose **Yes**, install a ribbon before printing. If you choose **No**, do not install a ribbon before printing. If you choose **High Energy** the printer displays the warning message, "High Energy ribbon can damage the printhead". Press **ENTER** to clear the warning.

Using a High Energy Ribbon

High energy ribbon is an option for this printer. It enables you to print on high energy (TUFF-MARK®) supplies.

When you select high energy ribbon for the printer setting, you are setting the printer to a higher printing temperature. Select this setting only after you have loaded a high energy ribbon and supplies or it may damage the printhead.

Note: The high energy setting is lost when you turn off the printer; select a high energy ribbon every time you turn on the printer.

High Energy Ribbon Limitations

When using the high energy ribbon option:

- ◆ Use a print speed of 2.5 ips (inches per second).
- ◆ Printhead warranty is reduced to 100,000 inches.
- ◆ Serial bar codes cannot be printed.
- ◆ Do not use peel mode.
- ◆ No more than 20% of the supply should have print (black coverage).

CAUTION: The high energy ribbon may break or stick to the supply when more than 20% of the supply contains print.

- ◆ Only white high energy supply should be used for bar code printing.
- ◆ Reverse fonts cannot be used.
- ◆ A non-printing area of at least .1 inch (2.54 mm) must exist on the left and right edge of the ribbon.
- ◆ Do not print horizontal lines or bars.
- ◆ Graphics are limited.

Setting the Speed

You can change the print speed for bar codes or graphics. If you select "default", formats with serial bar codes automatically print at 2.5 ips and formats with parallel bar codes print at 6.0 ips.

Note: If you change the speed, you must resend your formats or turn the printer off and back on before the change takes effect.

To change the setting, from the Main Menu, select Setup, then Supply. Then, follow these steps.

1. Press ← or → until you see Speed.

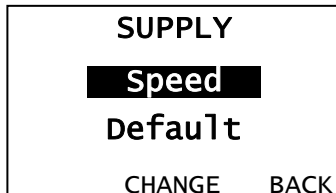

2. Press **CHANGE** to highlight the speed options. The current setting is shown.
3. Press ← or → to scroll through the speed setting options.

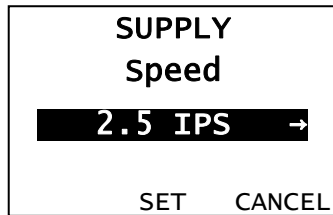

4. When you see the speed option you need, press **SET** to save the change. Press **CANCEL** to leave the speed option unchanged.
5. Press **BACK** until you return to the Home/Online screen.

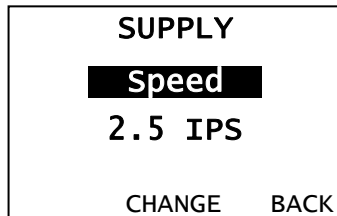

Setting the Feed Mode

You can use continuous, on-demand, or liner take-up printing. On-demand printing allows you to remove a label before printing the next one. Liner take-up collects the liner on a take-up reel located inside the printer's cover. See "[Using Optional Liner Take-Up](#)" for more information.

To change the setting, from the Main Menu, select Setup, then Supply. Then, follow these steps.

1. Press **←** or **→** until you see Feed Mode.

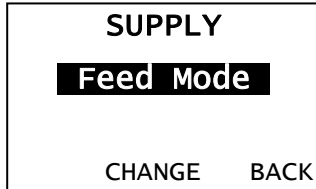

2. Press **CHANGE** to highlight the feed mode options. The current setting is shown.
3. Press **←** or **→** to scroll through the feed mode options.

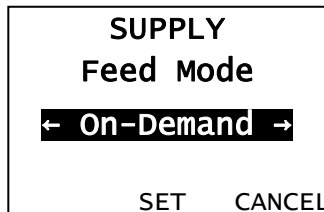

4. When you see the feed mode option you need, press **SET** to save the change. Press **CANCEL** to leave the feed mode option unchanged.
5. Press **BACK** until you return to the Home/Online screen.

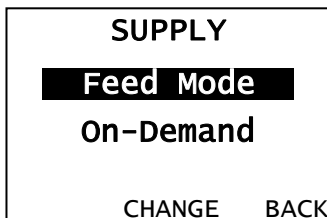

Setting the Backfeed

With backfeed turned on, the printer moves the supply backwards before printing.

To change the setting, from the Main Menu, select Setup, then Supply. Then, follow these steps.

1. Press **←** or **→** until you see Backfeed.

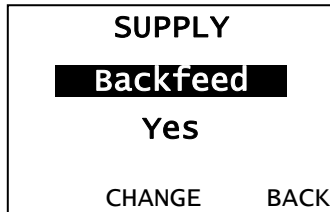

2. Press **CHANGE** to highlight the backfeed options. The current setting is shown.
3. Press **←** or **→** to scroll through the backfeed options.

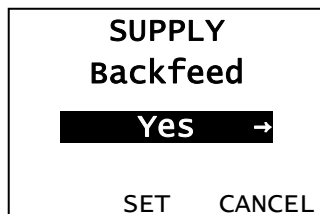

4. When you see the backfeed option you need, press **SET** to save the change. Press **CANCEL** to leave the backfeed option unchanged.
5. Press **BACK** until you return to the Home/Online screen.

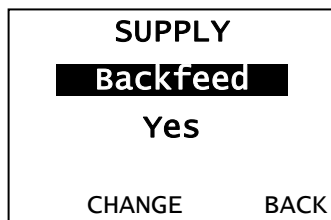

Note: If you choose **Yes**, make sure you use the Positioning menu options to set the backfeed distance. See "[Setting the Backfeed Distance](#)" for more information.

Changing the Position Settings

This menu includes selections to change the print, supply, margin, dispense, and backfeed distance positions. To change these settings, from the Main Menu, select Setup, Supply, Positioning.

Setting the Print Position

This function adjusts the vertical data printing position. Adjust the position if the print is too close to the top or bottom of the supply, or overtypes the pre-printed area. One dot equals 0.0049 inch.

- ◆ If the data is too close to the bottom, increase the number.
- ◆ If the data is too close to the top, decrease the number.

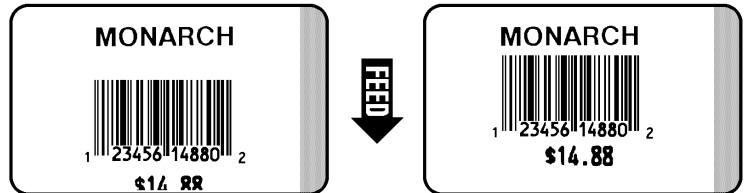

1. Press **←** or **→** until you see Print Pos.

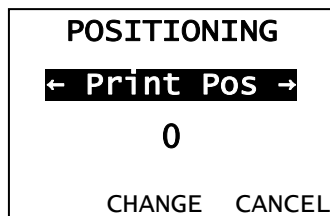

2. Press **CHANGE** to highlight the print positioning options.
3. Press **←** or **→** to increment/decrement the print position.

Note: Pressing the left function button changes the increment/decrement amount (changes by 1, 10, or 100).

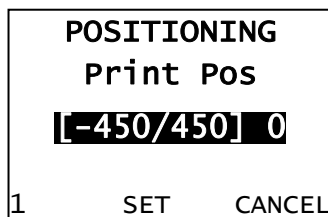

4. When you see the print position you need, press **SET** to save the change. Press **CANCEL** to leave the print position unchanged.
5. Press **BACK** until you return to the Home/Online screen.

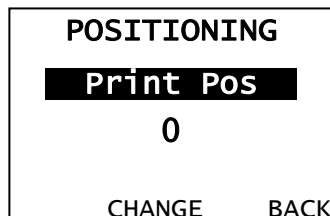

Note: Changing this setting only effects new formats sent to the printer.

Setting the Supply Position

This function adjusts the machine to print at the vertical 0,0 point on the supply. Adjust the supply in or out to easily remove the supply.

The adjustments are in dots (0.0049 inch).

- ◆ Increase the number to feed more supply out of the chute.
- ◆ Decrease the number to feed less supply out of the chute.

Note: The supply position adjustment should only be made on initial printer setup. For format adjustments, change the print position.

This option takes effect when you print the next label or tag. Changing supply position may also affect print position.

1. Press **←** or **→** until you see Supply Pos.

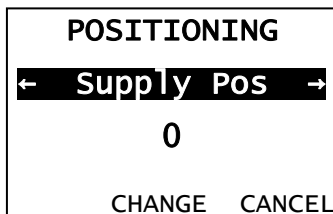

2. Press **CHANGE** to highlight the supply positioning options. The current setting is shown.
3. Press **←** or **→** to increment/decrement the supply position.

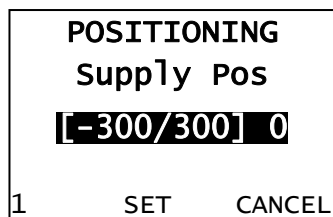

Note: Pressing the left function button changes the increment/decrement amount (changes by 1, 10, or 100).

4. When you see the supply position you need, press **SET** to save the change. Press **CANCEL** to leave the supply position unchanged.
5. Press **BACK** until you return to the Home/Online screen.

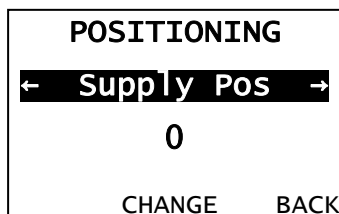

Setting the Margin Position

This function adjusts where the format prints horizontally on the supply. The adjustments are in dots (0.0049 inch), which is the smallest measurement the printer recognizes.

The width of the print area depends on your supply size. Maximum width is four inches. When you move the image to the right or left on the supply, avoid moving the image too close to either edge, because it may not print.

- ◆ If the data is too close to the left side, increase the number.
- ◆ If the data is too close to the right side, decrease the number.



Print too far to the left

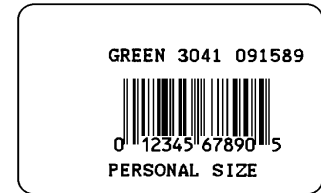

Print too far to the right

Note: Changing this setting only effects new formats sent to the printer.

To change the setting, from the Main Menu, select Setup, Supply, Positioning. Then, follow these steps.

1. Press ← or → until you see Margin Pos.

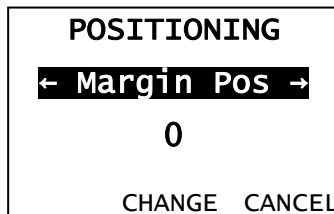

2. Press **CHANGE** to highlight the margin positioning options. The current setting is shown.
3. Press ← or → to increment/decrement the margin position.

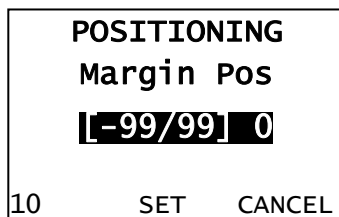

Note: Pressing the left function button changes the increment/decrement amount (changes by 1, 10, or 100).

4. When you see the margin position you need, press **SET** to save the change. Press **CANCEL** to leave the margin position unchanged.
5. Press **BACK** until you return to the Home/Online screen.

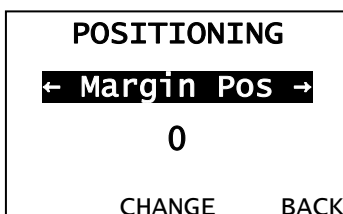

Setting the Dispense Position

This function adjusts the stopping point of the label.

To access this setting, from the Main Menu, select Setup, Supply, then Positioning.

Follow these steps.

1. Press ← or → until you see Dispense Pos.

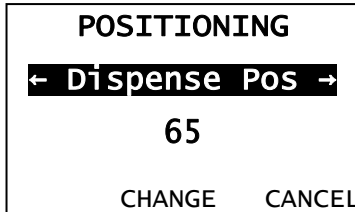

2. Press **CHANGE** to highlight the dispense positioning options. The current setting is shown.
3. Press ← or → to increment/decrement the dispense position.

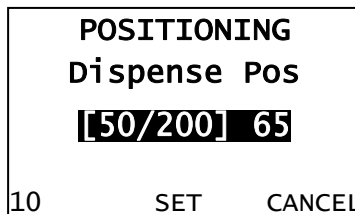

Note: Pressing the left function button changes the increment/decrement amount (changes by 1, 10, or 100).

4. When you see the dispense position you need, press **SET** to save the change. Press **CANCEL** to leave the dispense position unchanged.
5. Press **BACK** until you return to the Home/Online screen.

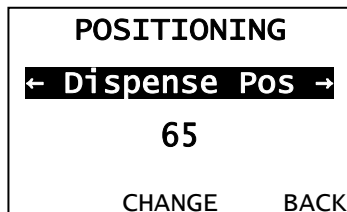

Setting the Backfeed Distance

Backfeed distance is the amount the label moves backwards. The backfeed distance should be equal to or less than the dispense position. If the backfeed distance is greater than the dispense position then the dispense position automatically changes to match the backfeed distance.

If you are tearing labels, instead of peeling, the backfeed distance must be 30 dots (0.15 inches) less than the dispense position to account for improper tearing of butt cut supplies. This causes a 30-dot non-print zone on the supply, but this prevents exposed adhesive under the printhead.

To access this setting, from the Main Menu, select Setup, Supply, then Positioning.

Follow these steps.

1. Press **→** until you see Backfeed Dist.

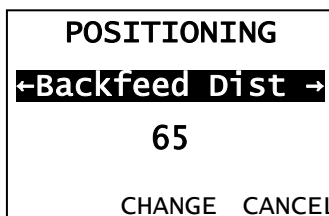

2. Press **CHANGE** to highlight the backfeed distance options. The current setting is shown.
3. Press **←** or **→** to increment/decrement the backfeed position.

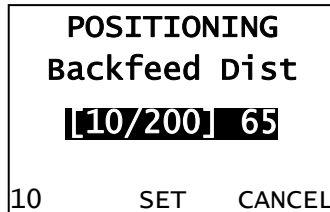

Note: Pressing the left function button changes the increment/decrement amount (changes by 1, 10, or 100).

4. When you see the backfeed distance you need, press **SET** to save the change. Press **CANCEL** to leave the backfeed distance unchanged.
5. Press **BACK** until you return to the Home/Online screen.

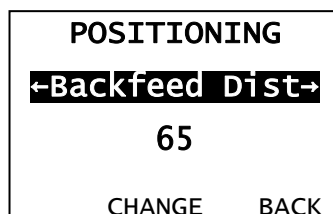

Using Batch Separators

A batch separator is an extra tag printed in between batches with a pinstripe pattern. For continuous supply, the batch separator is always six inches long. The name of the batch is shown on the batch separator.

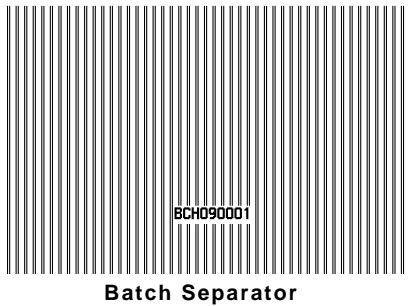

Note: Changing this setting only effects new formats sent to the printer.

To change the setting, from the Main Menu, select Setup, then Supply. Then, follow these steps.

1. Press **←** or **→** until you see Separators.

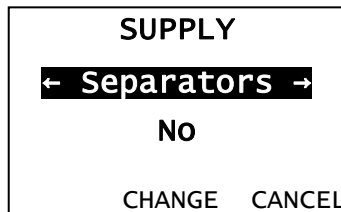

2. Press **CHANGE** to highlight the separator options. The current setting is shown.
3. Press **←** or **→** to view the separator options.

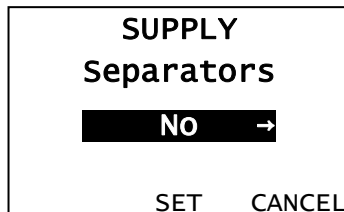

4. When you see the separator option you need, press **SET** to save the change. Press **CANCEL** to leave the separator option unchanged.
5. Press **BACK** until you return to the Home/Online screen.

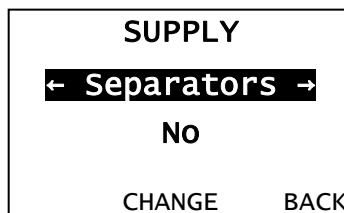

Using Skip Index

You can use the skip index mode to skip (or ignore) a sense mark and print an image over multiple labels, if necessary. For example, if you have 4.0" long supplies loaded, but your image is 8.0" long, enable skip index mode to print the 8.0" long image on two labels. The image length is determined by the format header. See your System Administrator or the optional *9906 Packet Reference Manual* for more information. The skip index feature is useful when you have a **single** format that contains two labels, such as a shelf label and a carton label.

Note: When designing the format, make sure text or graphics do not print in the gap of label rolls.

To access this setting, from the Main Menu, select Setup, then Supply.

1. Press ← or → until you see Skip Index.

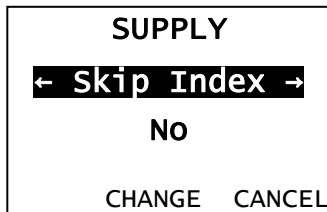

2. Press **CHANGE** to highlight the skip index options. The current setting is shown.
3. Press ← or → to increment/decrement the print position.

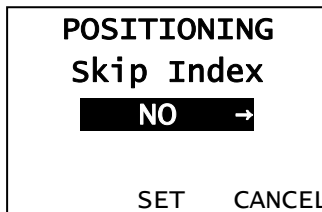

4. When you see the print position you need, press **SET** to save the change. Press **CANCEL** to leave the print position unchanged.
5. Press **BACK** until you return to the Home/Online screen.

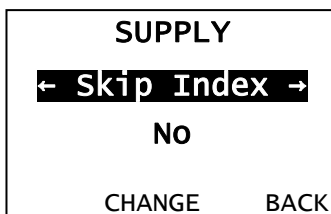

Using Rotate Image

Enabling this option rotates the printed image 180°. We recommend designing your formats as needed, so image rotation is not required. Make sure the loaded supply matches the image length and width or the rotated image does not print correctly.

Note: Changing this setting effects jobs sent to the printer after saving the change.

To change the setting, from the Main Menu, select Setup, then Supply. Then, follow these steps.

1. Press ← or → until you see Rotate Image.

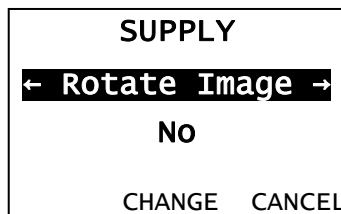

2. Press **CHANGE** to highlight the rotate image options. The current setting is shown.
3. Press ← or → to view the rotate image options.

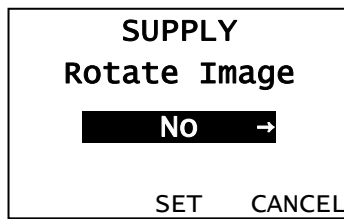

4. When you see the rotate image option you need, press **SET** to save the change. Press **CANCEL** to leave the rotate image option unchanged.
5. Press **BACK** until you return to the Home/Online screen.



Setting the Print Contrast

The print contrast controls print darkness on your supply. The range is **-699** to **+699**; the default is **0**. Having the correct print contrast setting is important because it affects how well your bar codes scan and how long your printhead lasts. High contrast settings may require additional printhead cleaning, create bar code growth, and/or lead to reduced scanning.

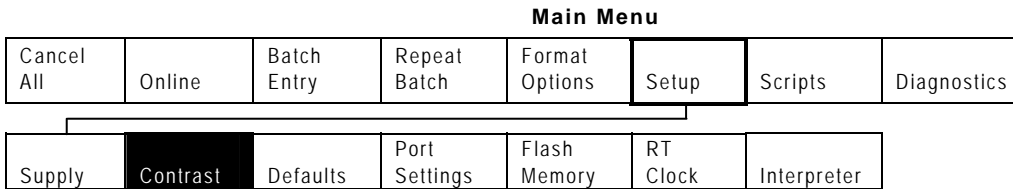

To change this setting from the Main Menu, select Setup.

1. Press **←** or **→** until you see Contrast.

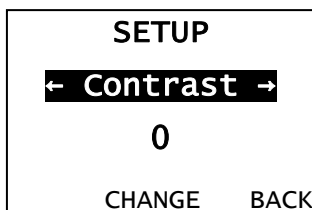

2. Press **CHANGE** to view the contrast setting options. The current setting is shown.
3. Press **←** or **→** to scroll through the contrast options. Increasing the contrast setting darkens the print; decreasing the contrast setting lightens the print.

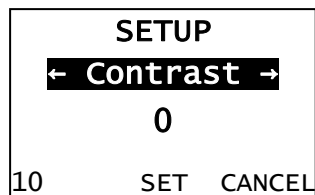

Note: Pressing the left function button changes the increment/decrement amount (can adjust to change by 1, 10, or 100).

4. When you see the contrast setting is on the display press **SET** to save the change. Press **CANCEL** to leave the contrast setting unchanged.
5. Press **BACK** until you return to the Main Menu.

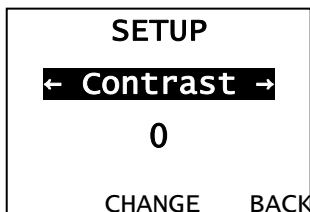

SETTING COMMUNICATIONS

This chapter tells you how to set the serial communication values. These values provide the link for normal online printing.

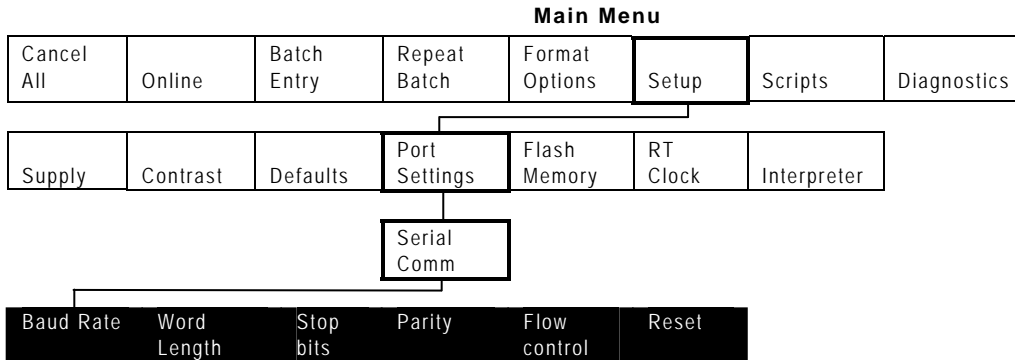

You need to set your Serial Comm values to match your computer's online communications. Before entering the communication values, see your System Administrator.

The serial communication values are in the table below.

Option	Choices	Default
Baud rate	1200/2400/4800/9600/19200/ 38400/57600/115200	9600
Word length	7/8	8
Stop bits	1/2	1
Parity	None/Odd/Even	None
Flow control	None/Xon/Xoff/DTR/CTS	DTR
Reset	No/Yes	No

Setting the Baud Rate

Baud rate is the speed, in bits per second, at which the printer sends and receives data.

To change the setting, from the Main Menu select Setup, Port Settings, Serial Comm, then, follow these steps.

1. Press **←** or **→** until you see Baud Rate.

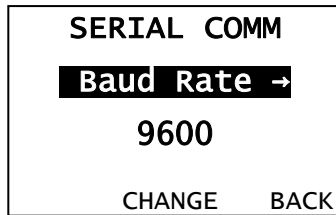

2. Press **CHANGE** to highlight the baud rate options. The current setting is shown.
3. Press **←** or **→** to scroll through the baud rate options.

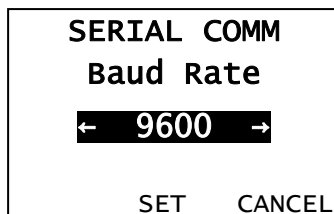

4. When you see the baud rate you need, press **SET** to save the change. Press **CANCEL** to leave the baud rate unchanged.
5. Press **BACK** until you return to the Home/Online screen.

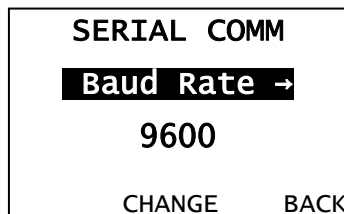

Setting the Word Length

Word length specifies the number of bits the printer uses to define a character.

To access this setting, from the Main Menu select Setup, Serial Comm. Then, follow these steps.

1. Press **←** or **→** until you see Word Length.

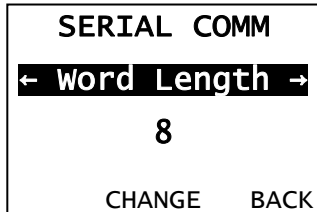

2. Press **CHANGE** to highlight the word length options. The current setting is shown.
3. Press **←** or **→** to scroll through the word length options.

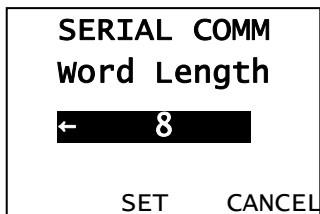

4. When you see the word length you need, press **SET** to save the change. Press **CANCEL** to leave the word length unchanged.
5. Press **BACK** until you return to the Home/Online screen.

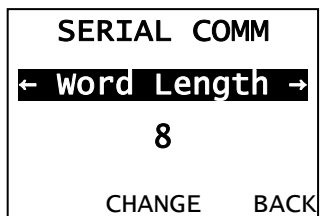

Setting the Stop Bits

A stop bit follows the data and parity bits to signal the end of a character.

To access this setting, from the Main Menu select Setup, Serial Comm. Then, follow these steps.

1. Press **←** or **→** until you see Stop bits.

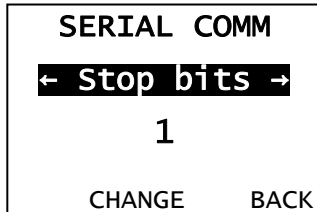

2. Press **CHANGE** to highlight the stop bit options. The current setting is shown.
3. Press **←** or **→** to scroll through the desired stop bits options.

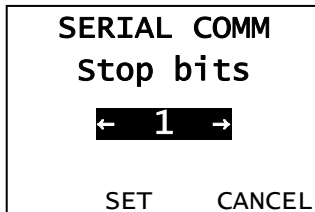

4. When you see the stop bits option you need, press **SET** to save the change. Press **CANCEL** to leave the stop bits unchanged.
5. Press **BACK** until you return to the Home/Online screen.

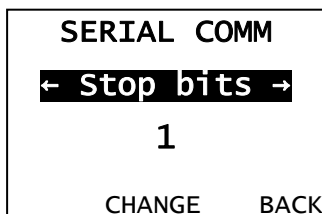

Setting the Parity

Parity checks the validity of data entering the printer. The parity bit immediately follows the last data bit for a character. The computer adjusts the parity bit according to the parity so the data bits in the character, with the parity bit, form an odd or even number of bits.

To access this setting, from the Main Menu select Setup, Serial Comm. Then, follow these steps.

1. Press **←** or **→** until you see Parity.

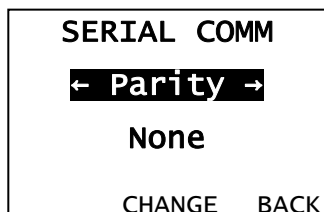

2. Press **CHANGE** to highlight the parity options. The current setting is shown.
3. Press **←** or **→** to scroll through the parity options.

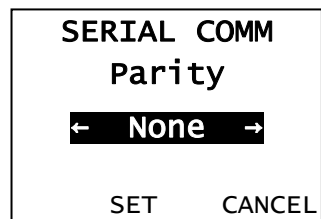

4. When you see the parity setting you need, press **SET** to save the change. Press **CANCEL** to leave the parity setting unchanged.
5. Press **BACK** until you return to the Home/Online screen.

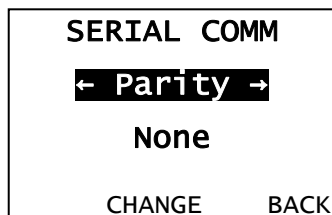

Setting the Flow Control

Data flow control is the method the printer uses to tell the computer whether it is ready to accept data. Data Terminal Ready (DTR) flow control is the most common.

To access this setting, from the Main Menu select Setup, Serial Comm. Then, follow these steps.

1. Press ← or → until you see Flow control.

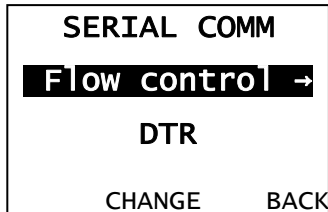

2. Press **CHANGE** to highlight the flow control options. The current setting is shown.
3. Press ← or → to scroll through the flow control options.

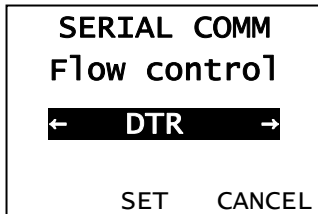

4. When you see the flow control setting you need, press **SET** to save the change. Press **CANCEL** to leave the flow control unchanged.

Note: XON is 17; XOFF is 19. Set flow control to DTR for PC computers (unless you have XON/XOFF software).

5. Press **BACK** until you return to the Home/Online screen.

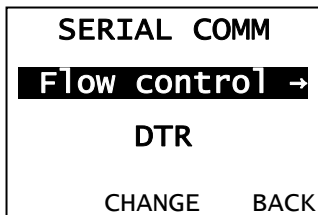

Resetting to Default Values

Use this setting to reset the printer's communication values to the defaults listed at the beginning of this chapter.

To access this setting, from the Main Menu select Setup, Serial Comm. Then, follow these steps.

1. Press **←** or **→** until you see Reset.

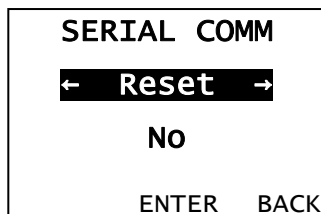

2. Press **CHANGE** to highlight the reset options.

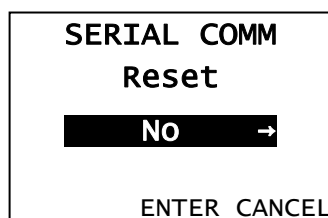

3. Press **←** or **→** to scroll through the reset options.
4. When you see the reset option you need, press **ENTER**. Press **CANCEL** to leave the reset option unchanged.

Note: Selecting "Yes," resets the baud, parity, word length, and stop bit to factory default.

If you chose yes, to reset the values, press **ENTER** to verify.

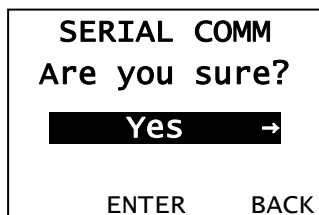

5. Press **BACK** until you return to the Home/Online screen.

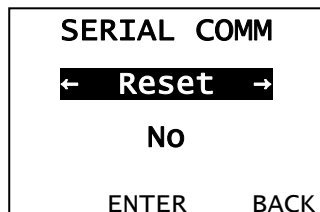

SETTING DEFAULTS

This chapter explains how to select the monetary sign, secondary sign, decimal places, slashed zero, power-up mode, prompt set, imaging errors, ignore configuration packets, and error retry. This chapter also explains how to format flash, check the available flash memory, and pack flash memory.

Main Menu

Cancel All	Online	Batch Entry	Repeat Batch	Format Options	Setup	Scripts	Diagnostics			
Supply	Contrast	Defaults	Serial Comm	Flash Memory	RT Clock	Interpreter				
Monetary Sign	Secondary Sign	Decimal Places	Slashed Zero	Power-up Mode	Prompt Set	Numeric Format	Flash Storage	No Image Error	Ignore Config	Error Retry

You can set your printer configurations to fit your daily operation, using either the offline menus or the online configuration option. After an option is selected in the online configuration or offline Setup Menu, the option is saved when the printer is turned off.

The monetary formatting options are in the table below.

Option	Choices	Default
Monetary sign	None, \$ Dollar, £ Pound, ¥ Yen, ₣ Deutsche Mark, F Franc, P Peseta, L. Lira, Kr Krona, ₯ Markka, ₤ Shilling, Rs Rupee, ⱶ Ruble, ₩ Won, ฿ Baht, ¥ Yuan, € Euro	\$ Dollar
Secondary Sign	No/Yes	No
Decimal Places	0/1/2/3	2
Slashed Zero	No/Yes	No
Power-up Mode	Online/Offline	Online
Prompt Set	English/French/German/Spanish-ES/Japanese/Portuguese/Italian/Swedish/Spanish Latin America/Danish/Dutch/Finnish/Norwegian/Polish/Turkish/Simplified Chinese	English
Numeric Format	Default, Arabic-Indic, Eastern Arabic	Default
Flash Storage	Disabled/Enabled	Disabled
No Image Error	Disabled/Enabled	Disabled
Ignore Config	Disabled/Enabled	Disabled
Error Retry	Disabled/Enabled	Enabled

The monetary sign, secondary sign, and decimal places options are used in conjunction with option **42**. Refer to the *9906 Packet Reference Manual* for more information.

Note: The settings for Monetary Sign, Secondary Sign, Slashed Zero, and Decimal Places apply when a format is downloaded. Changing the settings does **not** effect batches already in the printer.

You can also select **None** if you do not want a monetary sign to print in price fields.

Setting the Monetary Sign

To access this setting, from the Main Menu, select Setup, then Defaults.

Then, follow these steps.

1. Press **←** or **→** until you see Monetary Sign.

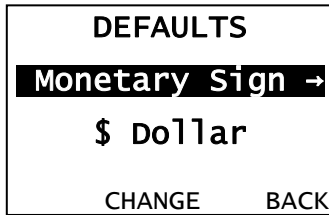

2. Press **CHANGE** to highlight the monetary sign options. The current setting is shown.
3. Press **←** or **→** scroll through the desired monetary sign options.

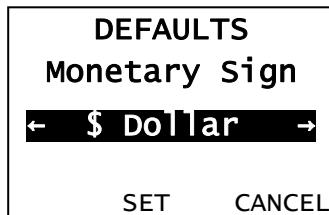

4. When you see the monetary sign option you need, press **SET** to save the change. Press **CANCEL** to leave the monetary sign unchanged.

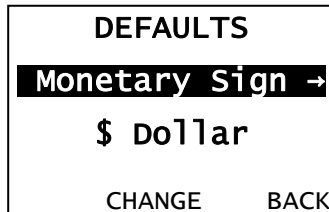

5. Press **BACK** until you return to the Home/Online screen.

Setting the Secondary Sign

If you select the dollar as the monetary sign, you can print amounts less than \$1.00 either by using a dollar sign and decimal (\$0.30) or by using a cent sign (30¢).

- ◆ If you set the secondary sign option to **No**, prices under \$1.00 will print like this: **\$.45**
- ◆ If you set the secondary sign option to **Yes**, prices under \$1.00 will print like this: **45¢**

The same option applies to the appropriate secondary sign for monetary signs other than the dollar.

To change the setting, from the Main Menu, select Setup, then Defaults. Then, follow these steps.

1. Press **←** or **→** until you see Secondary Sign.

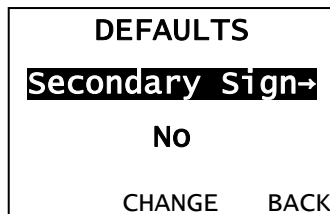

2. Press **CHANGE** to highlight the secondary sign options. The current setting is shown.
3. Press **←** or **→** to scroll through the secondary sign settings

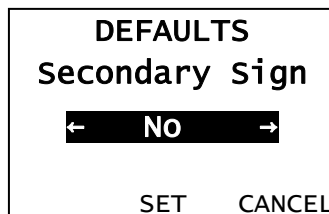

4. When you see the secondary sign setting you need, press **SET** to save the change. Press **CANCEL** to leave the secondary sign setting unchanged.
5. Press **BACK** until you return to the Home/Online screen.

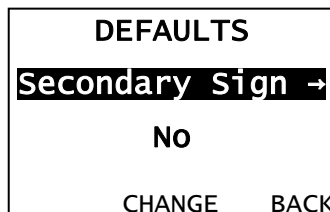

Setting the Number of Decimal Places

You can set the printer for 0, 1, 2, or 3 places after the decimal in a price field. In dollar currency, you might print prices like this: \$24.00 (2 decimal places) or like this: \$24 (0 decimal places).

1. Press **←** or **→** until you see Decimal Places.

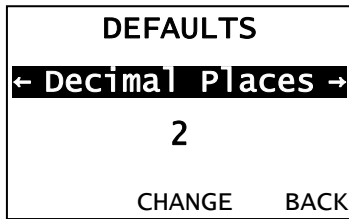

2. Press **CHANGE** to highlight the decimal place options. The current setting is shown.

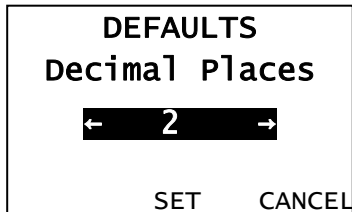

3. Press **←** or **→** to scroll through the decimal place options.
4. When you see the decimal place setting you need, press **SET** to save the change. Press **CANCEL** to leave the decimal place setting unchanged.

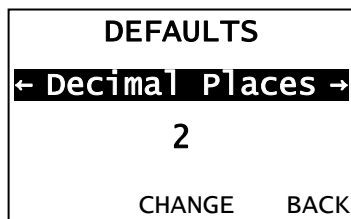

5. Press **BACK** until you return to the Home/Online screen.

Setting the Slashed Zero Appearance

The slashed zero feature lets you select how you want the zero character printed; either without a slash, 0 or, with a slash, Ø.

Standard or reduced fonts print the slashed zero character (Ø). Bold and OCR fonts print the standard zero (0) only. The slashed zero selection does **not** take affect until the format is sent to the printer again. If you change the way zero prints, you must resend your formats.

To access this setting, from the Main Menu, select Setup, then Defaults. Then, follow these steps.

1. Press **←** or **→** until you see Slash Zero.

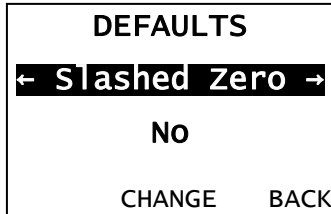

2. Press **CHANGE** to highlight the slashed zero options. The current setting is shown.

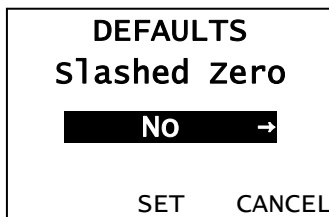

3. Press **←** or **→** to scroll through the slashed zero options.
4. When you see the slash zero option you need, press **SET** to save the change. Press **CANCEL** to leave the slash zero setting unchanged.

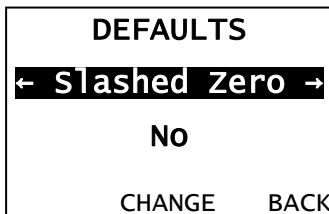

5. Press **BACK** until you return to the Home/Online screen.

Setting the Power-Up Mode

Power-up mode lets you decide how your printer starts each time you turn it on. If you want the printer to be ready to start printing when it is turned on, use the Online power-up mode. If you want the operator enter data before printing, use the Offline power-up mode.

To change the setting, from the Main Menu, select Setup, then Defaults. Then, follow these steps.

1. Press **←** or **→** until you see Power-up Mode.

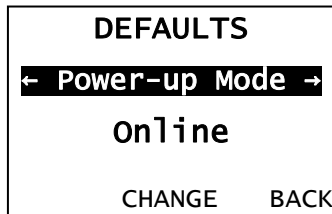

2. Press **CHANGE** to highlight the power-up mode options. The current setting is shown.
3. Press **←** or **→** to scroll through the power-up mode options.

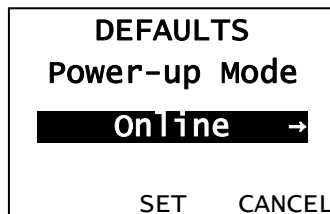

4. When you see the power-up mode you need, press **SET** to save the change. Press **CANCEL** to leave the power-up mode unchanged.

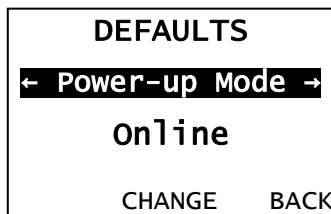

5. Press **BACK** until you return to the Home/Online screen.

Changing the Prompt Set

Prompt set determines which language displays on the printer's menu. You can select English, French, German, Spanish-ES, Japanese, Portuguese, Italian, Swedish, Spanish-LA, Danish, Dutch, Finnish, Norwegian, Polish, or Turkish Simplified Chinese. Some prompts may remain in English, even if you select a different language.

To change the setting, from the Main Menu, select Setup, then Defaults. Then, follow these steps.

1. Press **→** until you see Prompt Set.

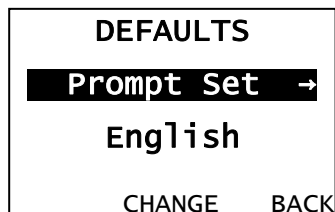

2. Press **CHANGE** to highlight the prompt set options. The current setting is shown.

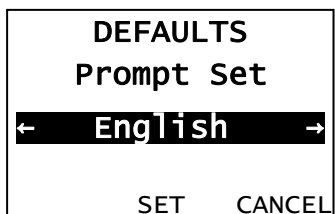

3. Press **←** or **→** to scroll through the prompt set options.
4. When you see the prompt set you need, press **SET** to save the change. Press **CANCEL** to leave the prompt set unchanged.

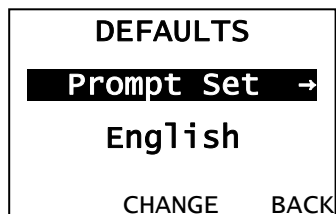

5. Press **BACK** until you return to the Home/Online screen.

Note: This option only affects the prompts; it does not affect what prints.

Setting the Numeric Format

Numeric format determines how numeric values appear in your printed data.

The choices include Default, Arabic-Indic, and Eastern Arabic.

Default Latin numerals print in Latin; Arabic text prints in Arabic.

Arabic-Indic Latin numerals print in Arabic; Arabic text prints in Arabic.

Eastern-Arabic Latin numerals print in Arabic; Arabic text prints in Arabic.

Examples

Latin Characters: 95% cotton

Latin Numerals with Arabic Characters: %95 قطب

Arabic Numerals with Arabic Characters:

Arabic-Indic: %٦٨ بوليستر

Eastern-Arabic: %٤٨ بوليستر

To change the setting, from the Main Menu, select Setup, then Defaults. Then, follow these steps.

1. Press **←** or **→** until you see Numeric Format.

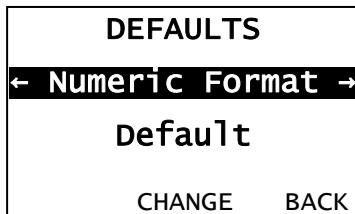

2. Press **CHANGE** to highlight the numeric format options. The current setting is shown.

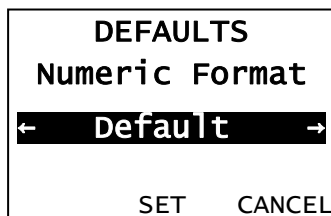

3. Press **←** or **→** to scroll through the numeric format options.
4. When you see the numeric format you need, press **SET** to save the change. Press **CANCEL** to leave the numeric format unchanged.
5. Press **BACK** until you return to the Home/Online screen.

Note: This option only affects the prompts; it does not affect what prints.

Using Flash Storage

Packets (formats, fonts, graphics) stored in flash memory are saved when the printer is turned off.

Note: You must format flash memory before enabling this option. Formatting flash memory is only required once during initial printer setup.

To change the setting, from the Main Menu, select Setup, then Defaults. Then, follow these steps.

6. Press **→** until you see Flash Storage.

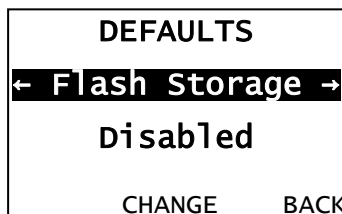

7. Press **CHANGE** to highlight the flash storage options. The current setting is shown.

8. Press **←** or **→** to scroll through the flash storage options

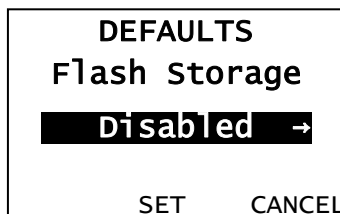

9. When you see the flash storage setting you need, press **SET** to save the change. Press **CANCEL** to leave the flash storage setting unchanged.

10. Press **BACK** until you return to the Home/Online screen.

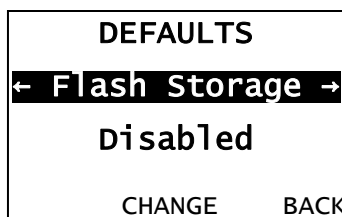

Using Flash Memory

The flash memory options are in the table below.

Option	Choices	Default
Format Flash	No/Yes	No
Unused Flash	NA	NA
Pack Flash	No/Yes	No

Formatting Flash Memory

Before storing packets in flash memory, downloading a script, or updating the printer's firmware, you must format the flash memory. **Formatting flash memory is only required once during initial printer setup.**

Note: When you format flash memory, the script and any downloaded TrueType® fonts saved in the printer's flash memory are deleted and must be resent to the printer.

To format flash memory, from the Main Menu, select Setup. Then, follow these steps.

1. Press ← or → until you see Flash Memory.

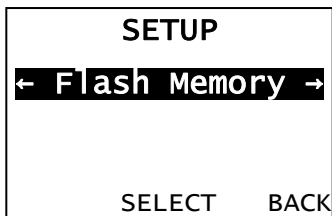

2. Press **SELECT** to highlight the flash memory options. The current setting is shown.

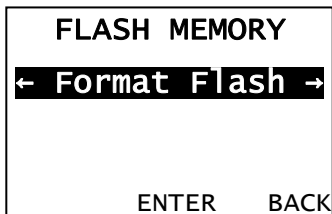

3. Press ← or → until you see Format Flash, then press **ENTER**.

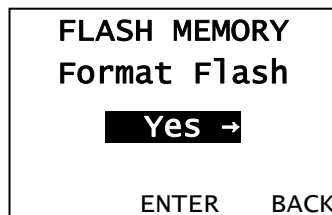

4. Press ← or → until you see Yes, then press **ENTER**.

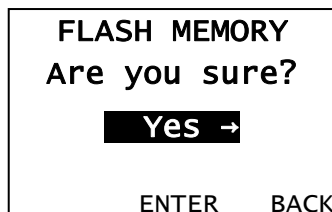

The printer's flash memory is cleared and reformatted. *This process may take several minutes.* The printer reboots automatically after formatting flash memory. You need to resend any fonts you want to use to flash memory again. You return to the Home/Online screen.

Checking Available Flash Memory

If you receive errors when downloading a script or other packets, make sure you have enough flash memory available.

Note: When you format flash memory, the script and any downloaded TrueType fonts saved in the printer's flash memory are deleted and must be resent to the printer.

To check available flash memory, from the Main Menu, select Setup. Then, follow these steps.

1. Press **←** or **→** until you see Flash Memory.

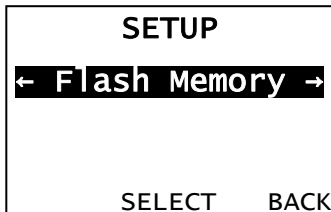

2. Press **SELECT** to highlight the flash memory options.
3. Press **←** or **→** until you see Unused Flash.

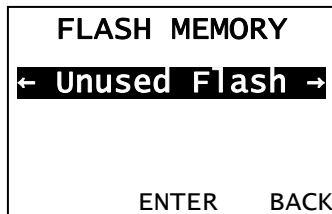

4. Press **ENTER** to view the current number (bytes) of available flash memory.
5. Press **BACK** until you return to the Home/Online screen.

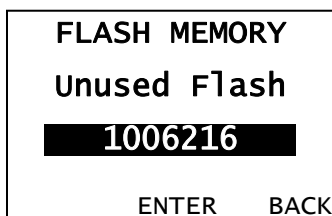

Packing Flash Memory

Packing flash memory permanently removes any deleted files from memory. Periodically select this option to "clean up" the printer's memory. Any deleted files are removed from memory when you pack flash.

To pack flash memory, from the Main Menu, select Setup. Then, follow these steps.

1. Press **←** or **→** until you see Flash Memory.

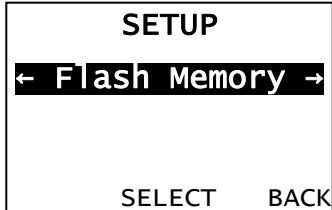

2. Press **SELECT** to highlight the flash memory options.
3. Press **←** or **→** until you see Pack Flash.
4. Press **ENTER** to highlight the pack flash options.

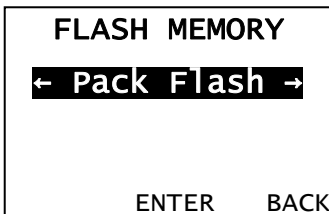

5. Press **←** or **→** until you see Yes.

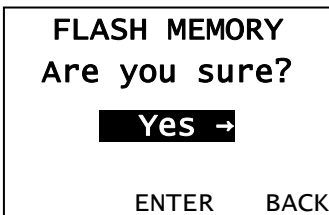

6. Press **ENTER** to permanently delete all files in flash memory.

Setting the Image Error Mode

Image errors can occur when there is a problem producing a complete label. Press **ESCAPE** to clear an image error.

Image errors include:

600	unable to image batch	614	portion of field off label
601	problem during imaging	615	invalid PDF417 bar code data
603	missing batch	618	invalid font size
611	invalid font, bar code or density	620	missing font data
612	missing batch data	621	invalid downloaded font
613	reference point off label	622	not enough font memory

Note: Enabling image errors means that if a format does not print as expected then no error is reported. For example, bar codes require a non-print zone; if a bar code is placed too close to the edge of the label, no error is reported and the bar code may not scan properly.

Error 616 (bar code dot shifting failed) is always reported.

To change the image error mode setting, from the Main Menu, select Setup, then Defaults. Then, follow these steps.

1. Press **←** or **→** until you see No Image Error.

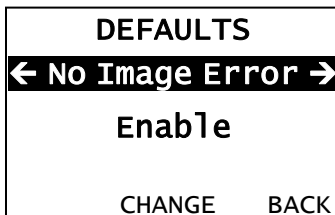

2. Press **CHANGE** to highlight the image error options. The current setting is shown.
3. Press **←** or **→** to scroll through the image error options.

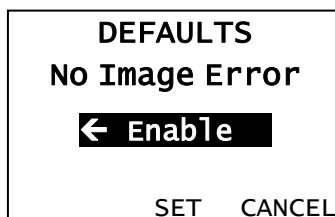

4. When you see the image error mode you need, press **SET** to save the change. Press **CANCEL** to leave the image error mode unchanged.

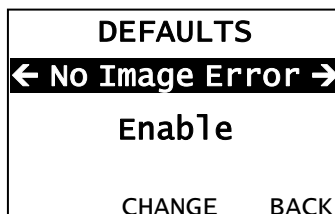

5. Press **BACK** until you return to the Home/Online screen.

Setting the Configuration Packet Mode

You can set how the printer responds to online configuration packets. You can ignore all online configuration packets by enabling this option. Ignoring these packets is useful when you cannot change your host's data or when you want the printer to operate as specified through the printer's menu.

Note: We recommend changing your host's data stream, but if that is not possible, enable this option.
Use caution if ignoring online configuration packets, because the printer may need the configuration for proper operation.

To change the setting, from the Main Menu, select Setup, then Defaults. Then, follow these steps.

1. Press **←** or **→** until you see Ignore Config.

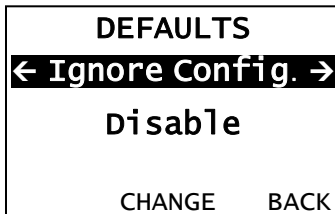

2. Press **CHANGE** to highlight the ignore configuration options. The current setting is shown.
3. Press **←** or **→** to scroll through the ignore configuration options.

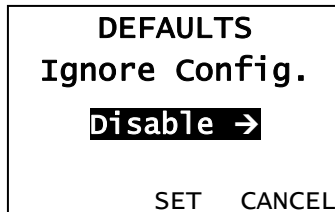

4. When you see the ignore configuration mode you need, press **SET** to save the change. Press **CANCEL** to leave the image error mode unchanged.

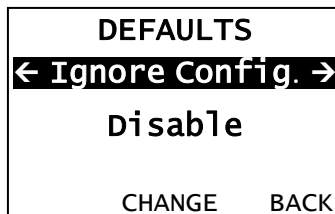

5. Press **BACK** until you return to the Home/Online screen.

Setting the Error Retry Mode

You can set how the printer operates after a supply error has been cleared. The printer can either reprint the job or discard/cancel the job. If you enable error retry, the printer reprints the job that was in process when the error occurred. If you disable error retry, the printer discards the job that was in process.

To change the setting, from the Main Menu, select Setup, then Defaults. Then, follow these steps.

1. Press **←** or **→** until you see Error Retry.

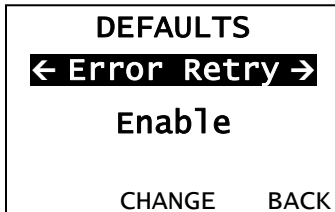

2. Press **CHANGE** to highlight the error retry options. The current setting is shown.
3. Press **←** or **→** to scroll through the error retry options.

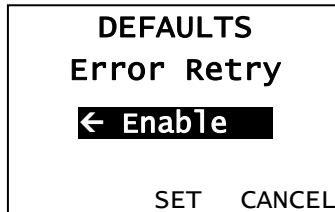

4. When you see the error retry mode you need, press **SET** to save the change. Press **CANCEL** to leave the error retry mode unchanged.

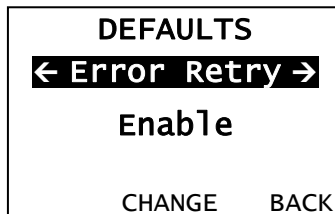

5. Press **BACK** until you return to the Home/Online screen.

Memory Guidelines

Use these basic guidelines when storing files in your printer's memory.

- ◆ Your printer has volatile RAM (packets deleted when the printer is off) and flash memory (packets saved when the printer is off).
- ◆ Flash memory must be formatted before any packets can be saved. See "Formatting Flash Memory" for more information.
- ◆ Formats, graphics, and check digits can be saved in flash (a copy is automatically placed in RAM). Any packets saved in flash cannot exceed the memory available in RAM.
- ◆ To print International fonts you must have the extended features printer. Save the font to the printer's flash memory.
- ◆ There is not a 1-to-1 ratio between the RAM memory (formats, graphics, and check digits) in your printer and the memory in your PC. For example, a file that is 5K in Windows may require 15-20K to store in your printer.
- ◆ Use temporary storage for graphics that are only used once or twice. However, if you have a logo that is used on multiple formats, save the graphic in flash.
- ◆ Each line in a packet requires the same amount of memory. The smaller the format, the less memory required to save it.

USING SCRIPTS

This chapter explains how to load, enable, and delete scripts. You can also enable status polling and immediate commands.

Using the Scripts menu requires custom software. Scripts can print data streams written for other printers or define a lookup table. Contact us to create a custom script for your printer.

Note: Ignore these menus if you do not use Scripts.

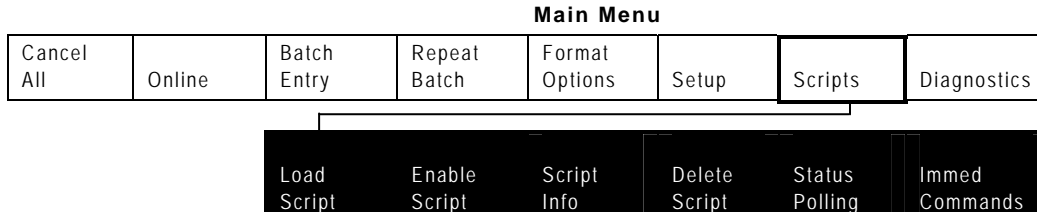

Your System Administrator may limit access to this menu to prevent changes. If password protection is on, the following is on the display when you try to access the scripts menu. To continue, ask your System Administrator for the password.

Enter Password	

ENTER	BACK

Initial Script Startup Procedures

Before you can start using a script, check the following items:

- ◆ Check to see if a script is already in the printer. See "[Viewing Script Information](#)" to continue.
- ◆ Format flash memory, if needed. See "[Formatting Flash Memory](#)" in Chapter 6 for more information.
- ◆ Download a script to the printer, if needed. See "[Downloading a Script](#)" to continue.

Viewing Script Information

To see if your printer has a script loaded, from the Main Menu select Scripts, then follow these steps.

1. Press **←** or **→** until you see Script Info.

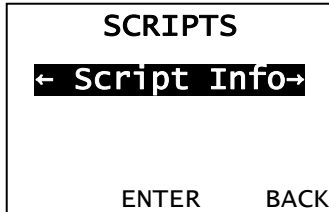

2. Press **ENTER** to highlight the script information options. The current setting is shown.

Note: If a script is not loaded, **ENTER** is disabled and you must press **BACK** and return to the previous menu.

3. Press **←** or **→** to scroll through the script information options.

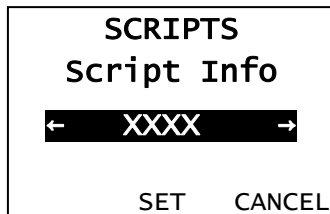

4. When you see the script information you need, Press **SET** to save the change. What you see depends on the script. If a script is not loaded, you see "No script loaded." If a script is loaded, you see the script name and version number.

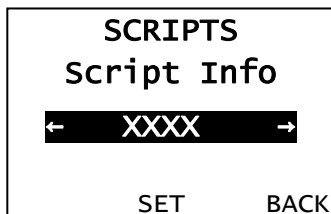

If a script is already loaded, see "[Enabling a Script](#)," to continue. If you need to download a script, see "[Formatting Flash Memory](#)" in Chapter 6.

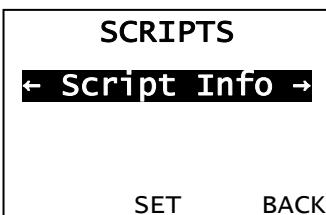

Downloading a Script

Follow these instructions to download a script from the MS DOS prompt. Set the communication parameters using the MODE command. Then, prepare the printer to accept a script. From the Main Menu select Scripts, then follow these steps.

1. Press ← or → until you see Load Script.

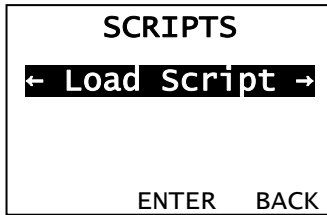

2. Press **ENTER** to enable the printer's script communication mode.

Note: Only one script can be loaded in the printer at a time.

When downloading a script, if you receive an error:

- ◆ Check the available flash memory. See "[Checking Available Flash Memory](#)" in Chapter 6 for more information.
- ◆ Format flash memory. See "[Formatting Flash Memory](#)" in Chapter 6 for more information.

After downloading a script, if the script does not appear to be loaded, try formatting flash memory and download the script again.

Enabling a Script

The script must be enabled before you can use it.

From the Main Menu select Scripts, then follow these steps.

To enable or disable a script:

1. From the Script Menu, press ← or → until you see Enable Script.

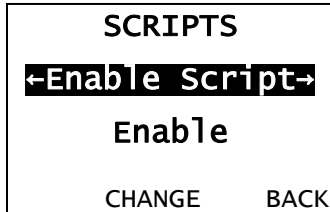

2. Press **CHANGE** to view the script enabling options.

Note: If a script is not loaded, **CHANGE** is disabled and you must press **BACK** and return to the previous menu. You see:

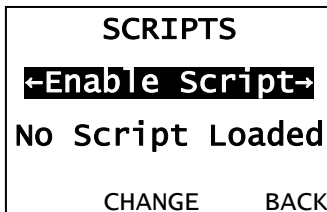

3. Press ← or → to display either **Enable** or **Disable**. Selecting "Enable" starts the script. Selecting "Disable" stops the script. If you select "Enable," when you turn off the printer and turn it back on, the script automatically starts.

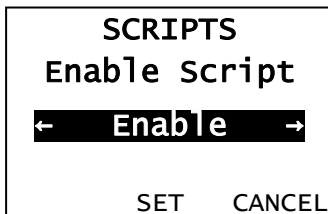

4. When you see the script enabling setting you need, press **SET** to save the change. Press **CANCEL** to leave the script enabling setting unchanged.
5. If you select "Enable", the printer automatically returns to the Home/Online screen and displays 'Script' in the upper left corner to indicate the printer has a script loaded and enabled.

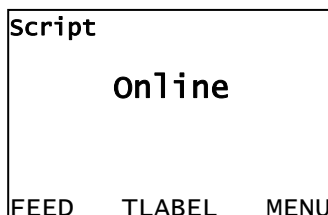

If "Disable" was selected, press **CANCEL** until you return to the Home/Online screen.

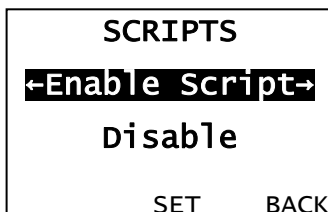

Deleting a Script

You can delete a script from the printer's memory.

From the Main Menu select Scripts, then follow these steps.

To delete a script:

1. From the Script Menu, press **←** or **→** until you see Delete Script.

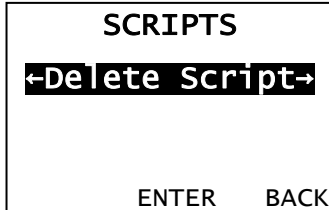

2. Press **ENTER** to start the script deletion process.

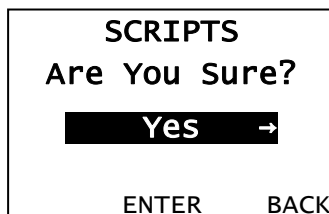

3. Press **←** or **→** to display either **Yes** or **No**. Selecting "Yes" deletes the script. Selecting "No" leaves the script on the printer.
4. When you see the script deletion setting you need, press **ENTER** to save the change. Press **BACK** to leave the script deletion setting unchanged.

Note: The flash memory used by the script is not available for other scripts or fonts until the flash memory is reformatted. However, when you format flash memory, you must resend the script and any downloaded fonts to the printer.

5. If "Yes" was selected, the printer automatically returns to the Home/Online.

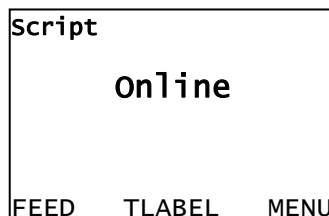

If "No" was selected, press **BACK** until you return to the Home/Online screen.

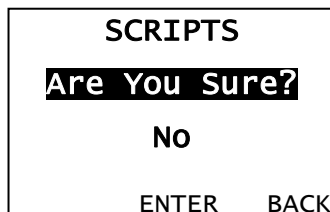

Enabling Status Polling

Status polling allows you to obtain information about the readiness of the printer and the current (or last received) print job. Your System Administrator can enable status polling while the printer is running in Script mode. From the Main Menu select Scripts then follow these steps to enable status polling.

1. Press **←** or **→** until you see Status Polling.

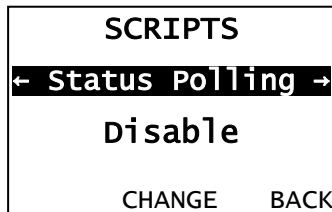

2. Press **CHANGE** to highlight the status polling options. The current setting is shown.
3. Use **←** or **→** to display either "ENABLE" or "DISABLE".

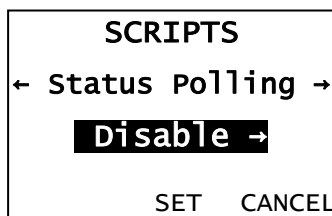

4. When you see the status polling setting you need, press **SET** to save the change. Press **CANCEL** to leave the status polling setting unchanged.
5. Press **BACK** until you return to the Home/Online screen.

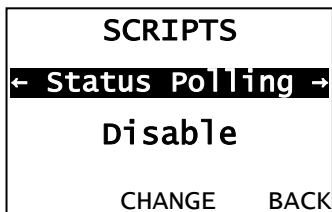

Using Immediate Commands

Your System Administrator can use immediate commands to reset the printer or cancel and repeat batches. Immediate commands are turned on or off through an MPCL packet. Your System Administrator should refer to the *9906 Packet Reference Manual* (available on our Web site) for more information about immediate commands and control characters.

Use this option to set whether the ADK script processes or ignores an immediate command control character.

To enable the ADK script to process immediate commands, from the Main Menu select Scripts then follow these steps.

1. Press **←** or **→** until you see Immed Command.

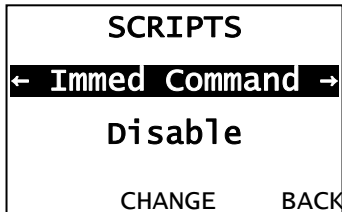

2. Press **CHANGE** to highlight the immediate command options. The current setting is shown.

3. Press **←** or **→** to select either "Enable" or "Disable".

- ◆ "Enable" allows the immediate command control character to be processed by the printer and performs the requested immediate command.
- ◆ "Disable" prevents the script and printer from processing the immediate command control character. Instead, the immediate command control character and immediate command are treated as data.

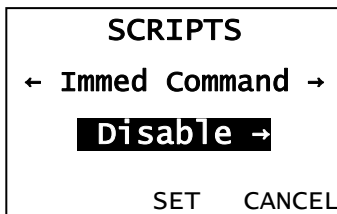

4. When you see the immediate command option you need, press **SET** to save the change. Press **CANCEL** to leave the immediate control setting unchanged.

5. Press **BACK** until you return to the Home/Online screen.

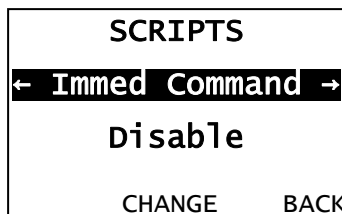

SETTING RFID OPTIONS

This chapter explains how to use the RFID factory installed option.

The 9906 printer with RFID has been engineered to program (encode) an RFID (Radio Frequency Identification) label (commonly called “RFID tags”) before the label’s format is printed. RFID tags contain an embedded RFID inlay (chip and antenna).

RFID is only available using die cut or black mark supplies. We do not recommend using Batch Separators or Skip Index with RFID supplies. A printer with RFID can print standard (non-RFID) supplies.

The printer supports Class 1 Generation 2 (C1Gen2) protocol encoding.



RFID supplies can be damaged by static electricity. Ground yourself by touching metal, such as the printer’s metal base, before handling the supplies.

The UHF radio operates in the 902 – 928 MHz frequency range in accordance with FCC Rules and Regulations.

Refer to the 9906 *RFID Application Notes* for information about programming an RFID tag.

To access the RFID settings, from the Main Menu select Setup, then RFID.

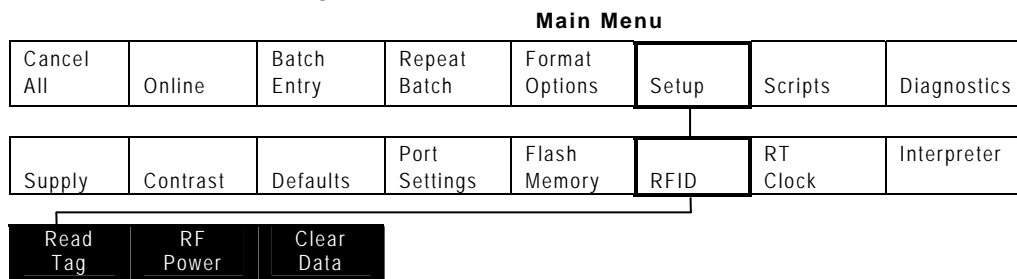

Option	Choices	Default
Read Tag	NA	NA
RF Power	Read/Write Value 7 – 27	-7
Clear Data	Yes/No	No

Using RFID Supplies

RFID supplies are available in a variety of sizes. Refer to the *9906 RFID Setup Guide & Supply Chart* for more information.

Do not modify the *Supply Position* when using RFID supplies with greater than a two-inch feed length. Doing so may move the RFID tag out of the RF Field's readable and programmable range. If necessary, you can modify the Print Position; however, make sure you do not move the tag out of the readable and programmable range.

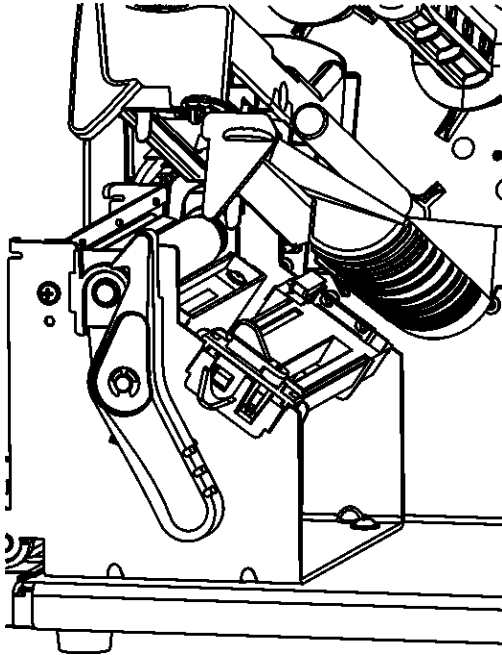

Using the RFID Setup Menu

Use the RFID Setup Menu to Read a tag, set the RF Power, and Clear Data.

Read Tag

Use this option to read the EPC data programmed into an RFID tag. You cannot read the user memory data.

To read a tag, from the Main Menu, select Setup, then RFID. Then follow these steps.

1. Press ← or → until you see

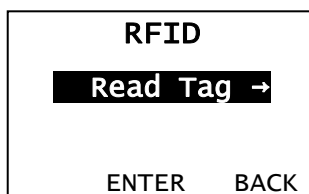

2. Lay the RFID tag you just programmed inside the supply path with the tag's antenna over the printer's box antenna (the box antenna is located behind the platen roller).
3. Press **ENTER**.

If the tag can be read, you see the EPC data, such as

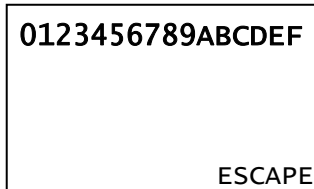

The programmed data is displayed in ASCII Hex format.

If the tag cannot be read “No Tag Found” appears briefly on the display. Try slightly moving the tag forward or back in the supply path over the box antenna and try again.

4. Press **BACK** until you see the Main Menu.

RF Power (Read/Write Value)

Use the RF Power menu to set the Read/Write value settings. The Read/Write value settings increase the strength of the RF Field emitted by the printer’s antenna. The higher the value, the greater the power of the RF Field.

For a complete list of inlays and value settings, refer to the *9906 Setup Guide and Supply Chart*.

CAUTION: Use extreme caution when increasing or decreasing the RF Power value because the RFID tags may become non-functional!

To change the settings, from the Main Menu, select Setup, then RFID. Then follow these steps.

1. Press ← or → until you see

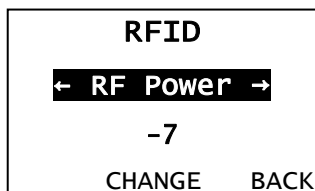

2. Press **CHANGE**.
3. Press ← or → to increase or decrease the setting. After you display the value you want, press **SET**. Press **CANCEL** to leave the RF Power unchanged.

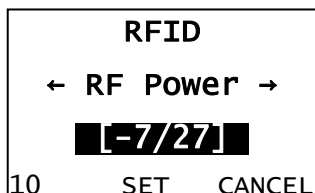

Note: Pressing the left function button changes the increment/decrement amount (can adjust to change by 1 or 10).

4. Press **BACK** until you see the Main Menu.

Clear Data

The printer keeps track and stores the following items that can only be cleared when you select “Yes” to clear data:

- ◆ The number of RFID tags successfully programmed.
- ◆ The number of RFID tags that failed programming.

Depending on your application and volume of labels printed, you may want to clear this data daily or after each batch.

To change the setting, from the Main Menu, select Setup, then RFID. Then follow these steps.

1. Press ← or → until you see

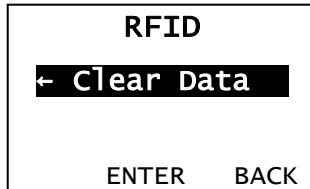

2. Press **ENTER**.
3. Press ← or → to see the other option. After you display the option you want, press **Enter**.
If you select “Yes,” all data collected since the last time it was cleared is erased.
If you select “No,” no data is erased.

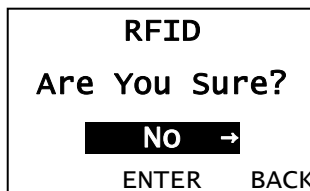

4. Press **BACK** until you see the Main Menu.

Printing a Configuration Label

The RFID configuration label displays the module’s Firmware and Hardware Versions, Module Type, Protocol, Read Value, Write Value, Region, Frequency, Good RFID Tags (number of RFID tags successfully programmed since last cleared), and Bad RFID Tags (number of RFID tags that failed programming since last cleared).

RFID Configuration	
01030240	Firmware Version
00000003	Hardware Version
ThingMagic	Module Type
Class1 Gen2	Protocol
-7	Read Value
-7	Write Value
USA (FCC Compatible)	Region
902 - 928 MHz	Frequency
0	Good RFID Tags
0	Bad RFID Tags

Depending on your application and volume of labels printed, you may want to print this configuration label daily or after each batch.

To print a configuration label, from the Main Menu select TLABEL, then follow these steps.

1. Press ← or → until you see.

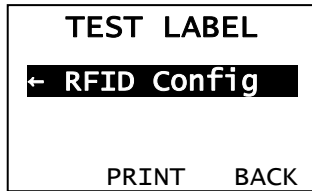

2. Press **PRINT**. Press **BACK** to return to the previous menu without printing a test label.

Setting the Error Action

The recovery action from an error condition is in the Setup, Supply menu. You can change how the printer responds to a bad RFID tag. The choices include normal (no overstrike) and overstrike/continue one to five consecutive bad scans. The overstrike pattern is created to prevent someone from using a bad label.

Selecting overstrike and continue 1x-5x sets the number of times the printer prints an overstrike pattern on consecutively bad labels before generating an error. The user must clear the error before operation can continue.

Note: Do not use the overstrike action with peel mode.

Normal (default)	The printer errors and the condition causing the error is displayed. The error must be cleared before operation can continue. An operator must press CANCEL to clear the error and continue printing. No overstrike pattern is printed.
Overstrike/Continue 1x	The printer prints an overstrike pattern on one, two, three, four, or five consecutive labels and stops printing after the selected number of overstrike patterns have been printed. An operator must press CANCEL to clear the error and continue printing. Do not use the label with the overstrike pattern.
Overstrike/Continue 2x	
Overstrike/Continue 3x	
Overstrike/Continue 4x	
Overstrike/Continue 5x	

Overstrike Example: Error action is set to overstrike/continue 3x:

If the printer errors on the first label, an overstrike pattern is printed, but the printer attempts to reprint the image up to three times. If the third consecutive label also generates an error, an overstrike pattern is printed; however, the printer stops and the error message is displayed. The operator must resolve the error condition before printing continues.

In the above example, if the third label did NOT generate an error,

- ◆ the batch image is printed
- ◆ the consecutive error counter is reset
- ◆ the printer continues processing the batch.

To change the setting, from the Main Menu, select Setup, then Supply. Then follow these steps.

1. Press ← or → until you see

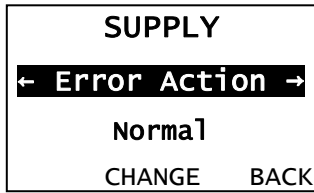

2. Press **CHANGE**.
3. Press ← or → to increase or decrease the setting. After you display the option you want, press **SET**. Press **CANCEL** to leave the RF Power unchanged.

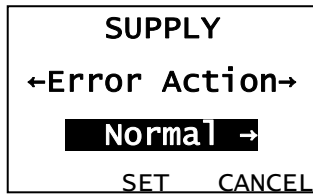

4. Press **BACK** until you see the Main Menu.

PRINTING

This chapter explains how to

- ◆ use on-demand mode printing.
- ◆ print, pause, restart, cancel, and repeat a batch.

You can send format, batch, and graphic data to the printer from a host. When the printer receives the data, batches begin printing automatically. The *9906 Packet Reference Manual* tells how to create, store, and download the data necessary to print batches. You can also use the Monarch® MPCL™ Toolbox utilities to create and download packets.

Printing

Before you print, make sure the printer is connected and ready to receive data.

1. Turn on the printer. Your printer is ready to receive and print batches when you see:

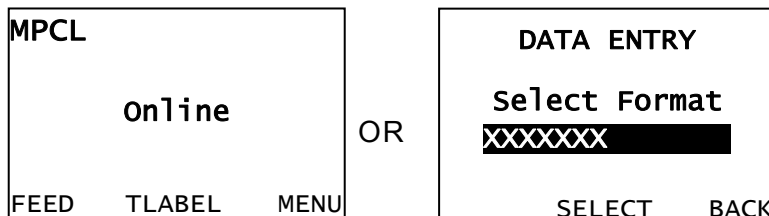

2. Download a format and a batch. Refer to the *9906 Packet Reference Manual* for information on downloading print jobs.
3. The printer prints a strip of labels.
4. Remove the printed labels.

Note: If the printer will be unused for extended periods of time, we recommend leaving the printhead unlatched.

We recommend you check the bar code print quality. A bar code that is in spec has complete bars, clear spaces, and small alphanumeric characters look complete. An in spec bar code may not look as good as one that is too dark, but it has the highest scan rate.



Printing a Test Label

Two different test labels can be printed:

- ◆ Printer Information (gives printer setting information)
- ◆ MPCL Label (gives printer setting information)

Printer Information

Contains system level generic information about the printer, including inch counts and printhead resolution.

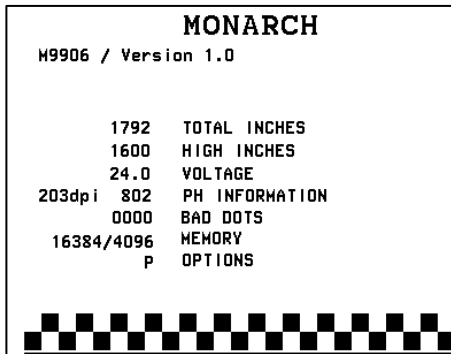

MPCL Label

Contains the current MPCL settings from the MPCL Online Configuration packet.

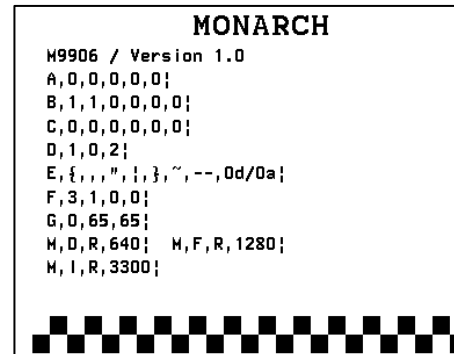

To print a test label, from the Main Menu select TLABEL, then follow these steps.

1. Press ← or → to scroll through the three test label options.

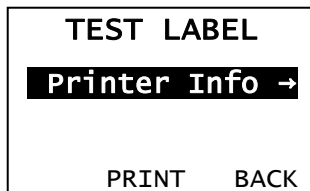

2. When you see the test label you need, press **PRINT**. Press **BACK** to return to the previous menu without printing a test label.

On-Demand Mode Printing

When the printer is operating in on-demand mode, the next label prints when the previous label is removed or when **FEED** is pressed. The display shows "Printing X of Y" until all labels in the batch print.

If you are using the optional peel module:

- ◆ you must use on-demand printing.
- ◆ remove excess liner by pulling up across the saw-toothed tear edge.
- ◆ hold the leading edge of peeled labels when printing on stock longer than six inches.
- ◆ minimum feed length is 1.5 inches.
- ◆ you must use non-perforated supplies.
- ◆ maximum speed is 8.0 ips.
- ◆ we recommend using 0.5-inch gap supplies when backfeed is disabled.

Pausing a Batch

Press **PAUSE** to interrupt printing. You may want to interrupt a batch to make adjustments for:

- ◆ Loading a different roll of supply or a ribbon. See Chapter 2, "[Loading Supplies](#)" or Chapter 3, "[Loading Ribbon](#)" for more information.
- ◆ Adjusting the supply position or contrast using the Setup menu. See Chapter 4, "[Setting Supply Options](#)" for more information.

When you press **PAUSE**, the following is on the display:

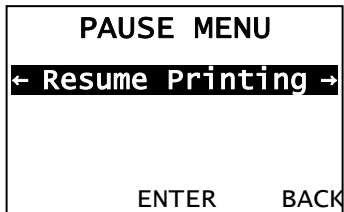

Press **ENTER** to resume printing or press **←** or **→** to display the Pause Menu options. The following chart shows the Pause Menu options.

Cancel Batch	Cancel All	Resume Printing	Restart Batch
--------------	------------	-----------------	---------------

Restarting a Batch

To reprint a paused batch from the beginning (using the original quantity), follow these steps.

1. Press **←** or **→** until you see Restart Batch.



2. Press **ENTER** to print the current batch from the beginning. Press **BACK** to resume printing.

Canceling a Paused Batch

To cancel a batch, press **ESCAPE** anytime while the batch is printing or press **PAUSE** and follow these steps.

1. Press **PAUSE** to interrupt printing.
2. Press **←** or **→** until you see Cancel Batch.

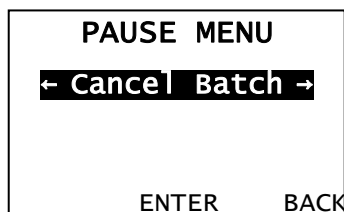

3. Press **ENTER** to cancel the current batch.

Canceling a All Batches

To cancel all batches that are in the print queue, follow these steps.

1. Press **PAUSE** to interrupt printing.
2. Press **←** or **→** until you see Cancel All.

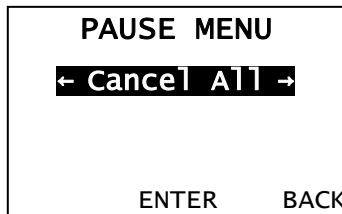

3. Press **ENTER** to cancel the all batches.

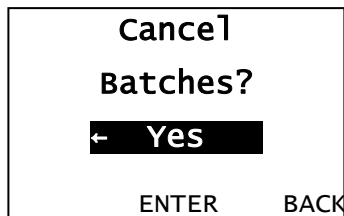

4. Press **←** or **→** to highlight the batch cancellation options.
5. Choose **Yes** and press **ENTER** to cancel all batches or choose **No** and press **ENTER** to resume printing.

Repeating a Batch

Before you start printing a new batch, you can reprint the last batch. The batch can be either the last one you printed completely or one that you canceled after starting to print.

1. From the Main Menu, press **←** or **→** until you see Repeat Batch.



2. Press **ENTER** to print a repeat batch.

Note: The number increments until the entire batch has printed. When it is finished, you return to the Home/Online screen.

Printing TrueType® Fonts

TrueType® fonts are available on this printer. TrueType fonts are scalable and the characters print smoothly, without the jagged edges you see on bitmap fonts. When downloading a TrueType font, you download the entire font. You cannot specify a subset (particular characters or point size) of the font.

This printer can accept a TrueType font file that has been converted to Hex or Run-Length encoding using the version of Font Utility. Font Utility is available on our Web site. Font Utility is a part of the Monarch MPCL Toolbox Utilities. You can also use a wide variety of Code Pages with International (Turkish, Latin, Spanish, etc.) characters. Using TrueType fonts allows you a greater range of fonts for your formats. TrueType fonts are designed to be regionally specific; therefore, all Code Pages may not be supported in a given font. Check with your System Administrator if you need to use TrueType fonts.

Licensing Your Fonts

We provide the Font Utility to help you create and download international code pages/characters. However, it is your responsibility to license the fonts you purchase and download to your printer. Contact your font supplier for licensing information.

Additional fonts that are compatible with this printer can be purchased from:

The Electronic Font Foundry; 11 Silwood Road; Ascot; SL5 OPY; England
(0)1344 875 201 www.eff.co.uk

This chapter tells you how to

- ◆ clear label jams and clean the printer.
- ◆ replace a printhead.

CAUTION: Do not use sharp objects to clean the printhead or touch the printhead with your fingers. This may damage the printer and require a service charge.

Clearing Label Jams

When a jam occurs, the display screen turns red and shows the error code(s). To clear the jam:

1. Turn off the printer and open the cover and printhead assembly.
2. If necessary, remove the label roll and ribbon.
3. Remove the jammed labels.
4. Reload the label roll and/or ribbon.
4. Close the printhead assembly and turn on the printer.
5. Press **FEED** to position the supply under the printhead.

Cleaning

The rate and frequency at which you print determines how often you must clean the printer. When you are using increased print contrast, we recommend cleaning the printhead after each ribbon. When you are using continuous supply, the printer displays "Clean Supply Sensor" after printing 60,000 inches of supply.

You may need to clean the printhead, sensor, and platen roller:

- ◆ if there is any adhesive build-up in the supply path.
- ◆ after printing approximately three rolls of thermal transfer/thermal direct supplies or after each ribbon.
- ◆ daily if your printer is in an excessively dirty, hot, or humid environment.
- ◆ if there are voids or streaking in the print as shown.



Voids



Streaks

Follow the instructions below to clean the printhead.

5. Turn off the printer, open the printer's cover and printhead assembly.
6. Remove the label roll and ribbon (when cleaning the printhead).
7. Press down on the exit cover tabs to open the exit cover on the front of the printer.

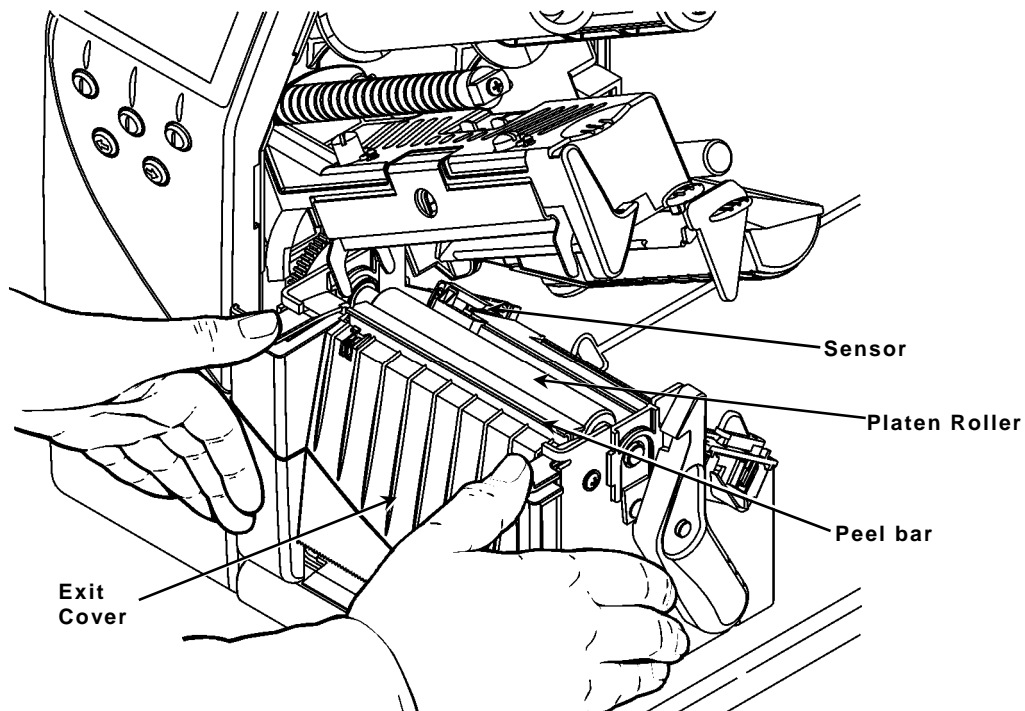

8. Spray the supply path, including the supply sensor, with compressed air to remove dust and debris.
9. Use a CLEAN-STRIP (part number 120350) to clean the platen roller, peel bar, printhead and sensor when you see significant adhesive build-up or after clearing a jammed label. Turn the platen roller with your finger to make sure it is clean all the way around. If adhesive remains, call Customer Service.

10. Once the printer is dry, reload the ribbon and label supplies.

11. Close the exit cover by pushing firmly on it. Both latches click into place.

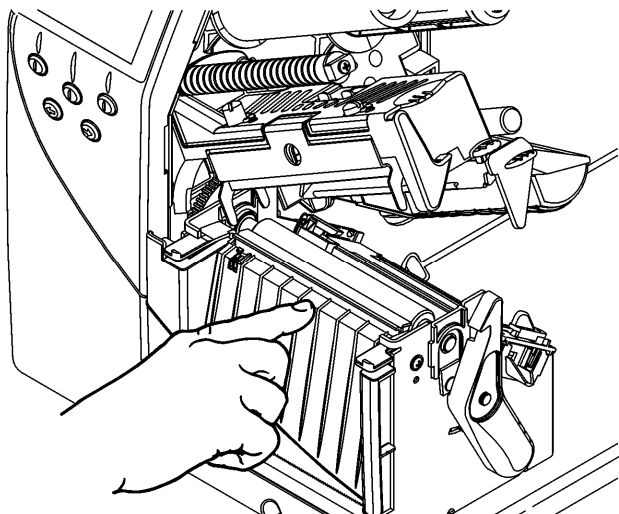

12. Close the printhead assembly and printer's cover.

13. Turn on the printer.

14. Press FEED to position the supply under the printhead. Resend your format, batch, and check digit packets.

Replacing the Printhead

You may have to replace the printhead if it is damaged or worn-out. For example, you may see error code 616 (bad dot or dots) or 768 (printhead failure). See Appendix B, "[Accessories & Options](#)" for the printhead part number.

CAUTION: The printhead is sensitive to static electricity, which can damage it or reduce its life. Ground yourself by touching metal, such as the printer's metal base, before touching the printhead. Clean the printhead prior to operation to remove any salt or oil left from handling.

To replace the printhead:

1. **Turn off the printer.**
2. Open the printer's cover.
3. Unlock the printhead by turning the retaining latch.
4. Lift the printhead assembly using the printhead tab until the assembly locks into place.
5. Remove the ribbon and supply.
6. Press forward and down on the two latches on top of the printhead assembly as shown. The printhead drops down.

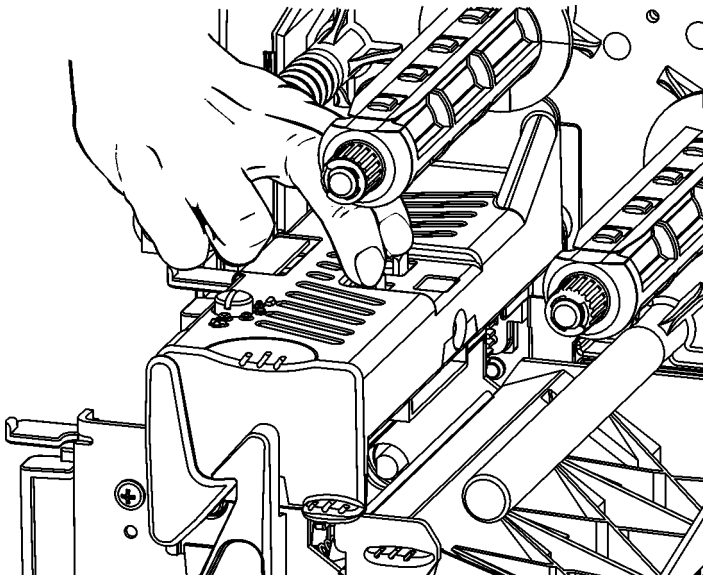

7. Carefully unplug the cable from the printhead as shown. Remember to ground yourself when touching the printhead.
8. Carefully plug the cable into the new printhead.

9. Align the new printhead with the tabs.

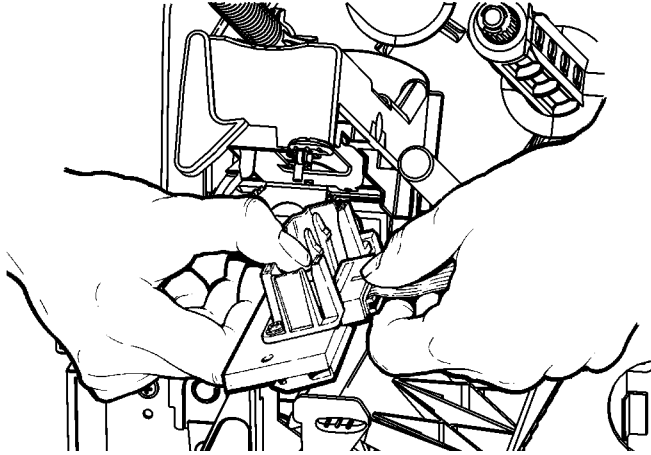

10. Snap the printhead into place.

Note: Make sure the printhead cable does not touch the ribbon roll.

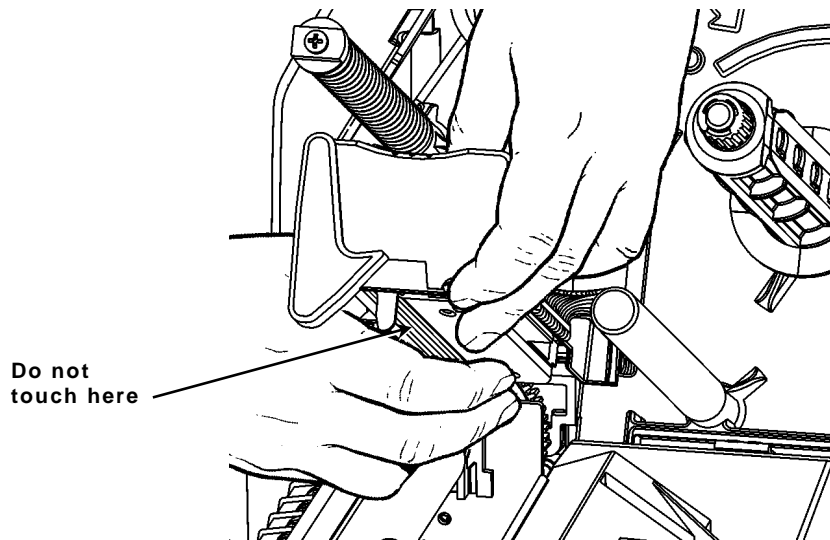

11. Clean the new printhead with a cotton swab dipped in isopropyl alcohol to remove any salt or oil left from handling.

12. Let the printhead dry and reload your supplies.

13. Close the printhead assembly and printer cover. Turn on the printer.

14. Press **FEED** to position the supply under the printhead.

Checking the Software Version

To view the software version information, from the Main Menu select Diagnostics, then follow these steps.

1. Press **←** or **→** until you see Version.

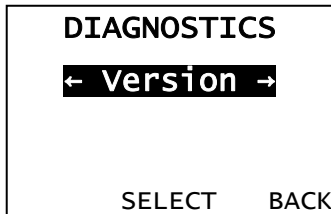

2. Press **SELECT** to highlight the version options.
3. Press **←** or **→** to scroll through the version options.

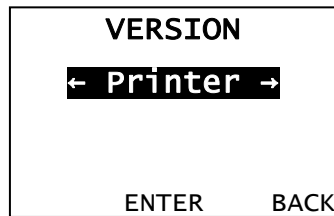

4. When you see Printer, press **ENTER** to view the information.
 - ◆ Item 1 is the printer model number.
 - ◆ Item 2 is the software version (press **ENTER** to view the third item).
 - ◆ Item 3 is the printer serial number.

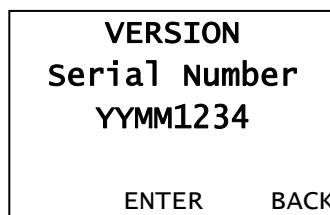
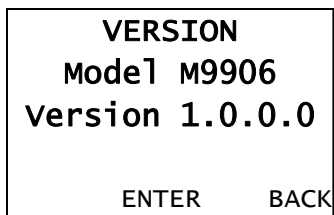

5. Press **BACK** until you return to the Home/Online screen.

Checking Supply Quality

The printer continuously stores data from 16 of the most recently printed supplies to check the reflectivity of the sensor marks on the supply. Before you check your supply quality, print a batch of supplies or test labels.

To check the supply quality, from the Main Menu select Diagnostics, then follow these steps.

1. Press **←** or **→** until you see User Diag.

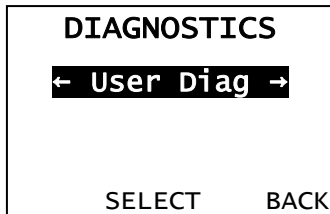

2. Press **SELECT** to highlight the user diagnostics options.
3. Press **←** or **→** to scroll through the user diagnostics options.

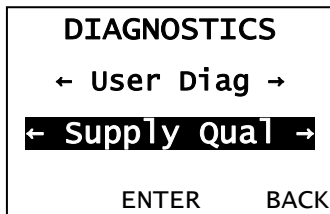

4. When you see Supply Quality, press **ENTER** to view the information.
 - ◆ If you have not printed any labels, the message "No data!" appears. Press **BACK** to continue.
 - ◆ You also see the "No data!" message if you are using continuous (non-indexed) supplies.
 - ◆ If you **have** printed labels since turning on the printer, the following will display

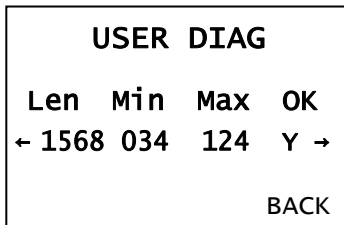

5. Press **←** or **→** to display the readings.
 - ◆ The Len listing is the length of the loaded supply in dots.
 - ◆ The Max listing should always be greater than the Min listing.
 - ◆ The OK listing tells whether the sense mark on the supply passed a detection test.
6. Press **BACK** until you return to the Home/Online screen.

Using Password Protection

The password protection feature prevents formats, graphics or fonts from accidentally being deleted from the printer's memory. *It also limits access to the Setup and Scripts menus.*

Enabling the Password (System Administrators only)

A System Administrator can enable the password that must be entered before formats, graphics or fonts can be deleted.

To enable the password from the Main Menu select Diagnostics then User Diagnostics. Then, follow these steps.

1. Press **←** or **→** until you see Password.



2. Press **ENTER** to enable/disable password protection.
3. Press **←** or **→** to highlight the password options. "No" is the default password protection setting, therefore it is always shown even if password protection is enabled.

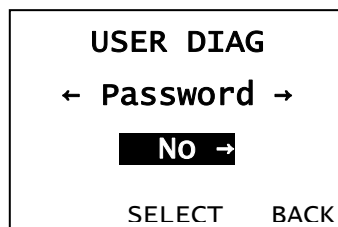

4. Choose **Yes** and press **SELECT** to enable password protection, then proceed to step 5.

Choose **No** and press **SELECT** (or press **BACK**) to proceed without password protection. You return to the User Diagnostics menu.

5. Enter the password (press **FEED** three times then **ENTER**).



Note: When password protection is enabled, a password is not required to clear batches, but it is required to clear formats, graphics, and fonts.

Service Diagnostics

The Service Diagnostics menu can only be accessed by a Service Representative; it requires a separate password. If you need to call Customer Service, print a test label first.

Troubleshooting

This section helps you correct some problems that may occur.

Problem	Action
Error message appears during startup.	Turn off the printer. Wait fifteen seconds and then turn on the printer. Call Customer Service if the error message reappears.
Does not print.	Check supply. Check ribbon. Send a correct format and batch packet.
Does not feed.	Adjust the printhead pressure dials.
Partially printed data.	Clean the printhead. Send a correct format packet.
Printing shadows or smears.	Clean the printhead. Change supply. Check ribbon.
Light printing.	Change supply. Adjust the print contrast. Adjust the printhead pressure dials. Check ribbon.
Heavy printing.	Clean the printhead. Change supply. Adjust the print contrast. Adjust the printhead pressure dials. Check ribbon.
Voids in printing.	Clean the printhead. Change supply type. Check ribbon.
Serial bar codes do not print.	Leave printhead unlatched when not in use. Use a print speed of 2.5 IPS. Adjust the print contrast.
Liner is wrapped around platen or peel roller.	Carefully remove the liner. Make sure the liner tears at the saw-toothed tear edge when using backfeed and peel mode.
When downloading a script, the printer errors.	Check the available flash memory. Format flash memory.
After downloading a script, the script does not appear to be loaded.	Try formatting flash memory, then download the script again.
'Clean Supply Sensor' message appears when using continuous supply.	Clean the supply sensor. See " Cleaning " in Chapter 9 for more information.

If you cannot fix a problem, call Customer Service.

Error Messages

You may receive the following types of error messages:

- ◆ Data Errors
- ◆ Communication Errors

Some errors numbered 400-438 and 500-574 are internal software errors. Errors numbered 900-999 are hard printer failures. If you cannot clear an error, turn off the printer, wait several seconds and then turn on the printer. For a complete list of errors, refer to the *9906 Packet Reference Manual* available on our Web site. Call Customer Service if you need additional assistance.

Common Errors

Errors 001 to 405 and 429 to 435 are data errors. This type of error indicates that incorrect data was sent to the printer and the printer is ignoring it. Your System Administrator should correct the packet and send it back to the printer.

Error	Description/Action
002	Name must be 1 to 8 characters (excluding non-printable control characters) inside quotes.
005	Invalid supply width.
018	Invalid code page selection
025	Data length is too long.
101	Format referenced by batch not in memory.
400	Invalid character following {.
403	Field separator was not found.
409	Printer memory is full. Delete unnecessary formats or graphics from memory.
410	Parity mismatch.
411	Framing error (baud rate mismatch).
412	Flow control mismatch.
413	Online receive buffer is full. Check for a flow control problem.
611	Font, bar code, or density in the batch does not fit the format.
612	The data in this line of the batch is either missing or does not match the format.
613	Reference point off supply.
614	Portion of field off supply or there may be an invalid character in the packet.
703	The printer sensed a calibration of different-sized black marks. Make sure the correct supply type is loaded.
704	Printer has not sensed a supply mark when expected or is out of supplies. Make sure your printer is set to the appropriate supply type. Change supply. Clean the sensor.
750	Printhead is overheated. Turn off the printer.

- 751 Printer did not sense a black mark when expected. For errors 751-753, check the supply tracking, supply marks, black mark sensor position, and supply roll for binding. Press **ESCAPE** and try to continue printing. Change supply.
- 752 Printer sensed a mark in the wrong place.
- 753 Printer sensed a mark that is too long.
- 754 Check for a ribbon jam or remove any slack in the ribbon by turning the take-up reel clockwise. Load a new ribbon.
- 755 Printhead is open. Close the printhead.
- 756 Load supply and/or clean the sensor.
- 757 Load supply (supply length mismatch), because the calibrated supply length differs by plus or minus .25 inches from the format. Press **FEED**.
- 758 The supply is not seen or the on-demand sensor is broken. Check for a label jam, clear the supply path, or reload supplies. This error may occur if you remove a label too quickly in the on-demand mode.
- 762 Low Voltage. For DC-powered printers, recharge the external battery. For AC-powered printers, check the power inlet where the printer is connected. The acceptable voltage range is between 90-132 V_{RMS} and 180-264 V_{RMS}. If more or less power is received, unpredictable results may occur.
- 763 Waiting to dispense label. Press **FEED**.
- 765 The printhead has less than 8 bad dots. The printer can shift bar code fields to avoid bad dots. You may need to press **ESCAPE** to continue printing. Print a test label to confirm the number of bad dots.
- 768 Printhead has more than 8 bad dots within the format area or is not connected. Connect the printhead.
- 785 The internal liner take-up reel is full. Remove the liner take-up reel and dispose of the liner. Press **ESCAPE** to continue printing.
- 786 Internal liner take-up error. The liner has separated from the core or is not properly winding on the core. Remove the liner from the take-up core and reload the liner into the take-up core.
- 791 The printer has an error pending. Turn off the printer. Wait 15 seconds (until the power light is completely dim) and turn it back on. Resend the packets.

SPECIFICATIONS

A

Printer

Height:	11 inches (279mm)
Width:	105 inches (267 mm)
Depth:	16.1 inches (409 mm)
Weight:	22 lb. (10 kg)
Shipping Weight:	25 lb. (11.4 kg)
Power Source:	90-264 V _{AC} with autoselect 50/60Hz
Operating Limits:	Thermal Transfer (ribbon): 40° to 95°F (4° to 35°C) Thermal Direct: 40° to 104°F (4° to 40°C) Storage: 15°F to 120°F (-10°C to 49°C) Humidity: 5% to 90% non-condensing
Printhead:	Thermal at 4.09 inches (103 mm) wide 203 dpi (8.0 dots per mm)
Printing Method:	Thermal Transfer (ribbon) or Thermal Direct
Print Speed:	2.5 ips (64 mm) default for all serial bar codes, 4.0 ips (102 mm) or 6.0 ips (152 mm) default for parallel bar codes
Max Print Area:	4.09 inches x 50.0 inches (102 mm x 1270 mm)

Supplies

For high temperature or high humidity environments, contact us for supply recommendations. Continuous (non-indexed) supply does not have perforations or black marks and must be used in continuous mode. Aperture supplies are tags or labels with holes (or openings) in them. The supply is sensed using the holes. The holes can be only on the edge of the supply.

Supply Types: Thermal Transfer or Direct

Supply Widths: 0.75 inches (19 mm) minimum
4.5 inches (114 mm) maximum

Supply Lengths: 0.50 inch (13 mm) minimum
50 inches (1270 mm) maximum

Tags

0.50 inch (13 mm) minimum
13.5 inches (343 mm) maximum
Note: Tags must contain perforations.

Total Thickness: 5.5 to 10 mils

Ribbon Specification

Do not leave ribbon in sunlight, high temperatures or humidity.

Ribbon Type: Standard (wax, high speed)
Premium (wax resin, TUFF-MARK® resin)

Ribbon Widths	Use with Max. supply width
1.5 inches (38 mm)	1.3 inches (33 mm)
1.8 inches (46 mm)	1.5 inches (38 mm)
2.3 inches (58 mm)	2.0 inches (51 mm)
3.3 inches (84 mm)	3.0 inches (76 mm)
3.5 inches (89 mm)	3.2 inches (81mm)
4.3 inches (110 mm)	4.0 inches (102 mm)
4.5 inches (114 mm)	4.5 inches (114 mm)

Ribbon Length: 17,700 inches (450 meters)

Ribbon Core: 1.0 inch (25.4 mm) cardboard core

About Ribbons

The width of the ribbon must be greater than the supply width. Since some supplies are more abrasive to printheads than others, using a ribbon wider than your supply helps protect the printhead.

Cable Pinouts

The following tables show the connector pins for a 9-pin to 9-pin (126716) cable.

9-Pin (M)	To	9-Pin (F)
SHIELD		SHIELD
1		1
RCV 3		3 RCV
TX 2		2 TX
CTS 6		6 CTS
RTS 4		4 RTS
DTR 8		8 DTR
DSR 7		7 DSR
+5V 9		9 +5V
SGND 5		5 SGND

ACCESSORIES & OPTIONS

Accessories

- ◆ 935™ External Rewind
- ◆ 939i™ Intelligent Keyboard
- ◆ USB mini keyboard (160001)
- ◆ 203 dpi(128933ST) & 300 dpi (12678401) Replacement Printhead Kit
- ◆ Monarch® MPCL™ Toolbox (utilities to configure the printer, download fonts, and design formats) available on our Web site
- ◆ Printhead CLEAN-STRIP (120350)
- ◆ Printhead Cleaning Pen (114226)
- ◆ Cables: 9-pin to 9-pin (126716)
- ◆ *9906 Packet Reference Manual* – Programmer's manual (TC9906PR)

Packaging Materials

If you need to ship the printer to a different location and do not have the original packaging, use the following part numbers to order the appropriate packaging materials.

Part Number	Description and Qty.
69601	Shipping carton (1)
69602	Foam cap, front (1)
69603	Foam cap, back (1)

Shipping the Printer

If you need to ship the printer to a different location:

1. Remove the ribbon roll, if one is loaded.
2. Remove the supply roll, if one is loaded.
3. Close the printhead by pressing down on the thumb well until it clicks into place.
4. Place the printer in the original box and secure with packaging material. **Make sure the printer is adequately packed to avoid damage during shipment.**

Factory-Installed Options

- ◆ Internal Ethernet with MonarchNet2™
- ◆ 802.11b/g wireless with MonarchNet2™
- ◆ Parallel port (IEEE-1284)
- ◆ 300 dpi printhead
- ◆ ADK script programming for special applications
- ◆ Tear bar with peel mode
- ◆ Peel mode with internal liner take-up

GLOSSARY



The following terms will help you use this manual.

continuous mode	Mode in which the printer prints all the labels in the batch without stopping.
download (send)	Transmission of data from the host to your printer.
format	Supply layout or design, which the <i>System Administrator</i> downloads as a format packet to your printer.
host	Any mainframe, minicomputer, data collect terminal, or personal computer sending data to the printer.
LCD	Display on the printer used to indicate printer conditions and problems.
leader	Wrap around a new roll of ribbon with printing on it.
on-demand mode	Mode in which the printer stops after each label to allow you to remove it.
print job (batch)	Actual data printed on a label or tag. The host may download the print job together with the format, or as a separate packet. The print job is also called a "batch."
online	Direct communication between a computer and the printer.
Supply Sensor	Senses whether supply is loaded or needs to be loaded in the printer. Located in the supply path.
Supplies	Labels used for printing.
System Administrator	Person responsible for creating and downloading packets.

INDEX

A

about fonts 8-5
Accessories 2
adjusting
 supply width 2-11
Adjusting Print Position..... 4-8
Adjusting Supply Position..... 4-9
Available Memory 6-11

B

Backfeed 4-7
Backfeed Distance..... 4-12
Batch 8-3
 repeating 8-4
 restarting 8-3
Batch Separator 4-13
Baud 1-3
Baud Rate 5-1, 5-2

C

Cancel
 paused batch 8-3, 8-4
 care & maintenance 9-1
Checking
 print 8-2
 software 10-2
Cleaning Printer..... 9-2
Clearing Jams 9-1
Common 10-6
Communication
 Errors 10-6
 Ethernet 1-3
 Parallel 1-3
 serial 1-3
Communication Parameters
 Baud Rate 5-1
 Parity 5-1
 Start (XON) Character 5-1
 Stop (XOFF) Character 5-1
 Stop Bits 5-1
 Word Length 5-1
Contrast
 setting 4-16

D

Decimal Places 6-4
Default
 port settings 5-1
Default Values 1-3, 5-1
Demand Mode..... 8-1
Diagnostics 10-1
Dispense
 position 4-11
Dispense Position..... 4-11
Display
 function buttons 1-4
 navigation buttons 1-4
Distance
 backfeed 4-12

Documentation
 ordering 1-2
Downloading
 scripts 7-3

E

Errors
 common 10-6
 communication..... 10-6
 messages 10-6
 summary 10-6
Exiting 1-4

F

feed mode 4-6
Feed Mode 4-6
Flash Memory 6-9
Flow Control..... 5-6
Font Licensing 8-5
Formatting
 flash memory 6-10
Function
 selecting 1-4

H

high energy ribbon 4-4

I

Immediate Commands..... 7-7

J

Jams
 clearing 9-1

L

labels
 adjusting for width 2-11
Labels
 clearing jams 9-1
 specifications 2
 test 8-2
Liner Rewind 2-8
Liner Take-Up 2-8
Loading
 labels 2-2
 peel mode 2-6
 ribbon 3-2
 tags 2-2
Loading Ribbon 3-1, 3-2
Loading Supply 2-1

M

Maintenance
 cleaning printer..... 9-2
Margin Adjustment 4-10
Memory 6-9
 flash 6-9

storage	6-9
Monetary Sign	
defining	6-2
MPCL	1-2

O

on-demand printing	8-2
Options	2

P

Parity	5-1, 5-5
Password	
protection	10-4
passwords	
setting	10-1
Paused Batch	
cancel	8-3, 8-4
Peel Mode	2-6
Port Settings	5-1
Power Cable	1-3
Connection	1-3
Power-Up	6-6
mode	6-6
Print	
adjusting position	4-8
setting contrast	4-16
Print Contrast	4-16
Print Speed	4-5
Printer	
checking status	1-4
Control Panel	1-4
defaults	4-1, 4-5, 4-14, 5-7, 6-1, 6-2, 6-9
display	1-4
establishing communication	1-3
operating specifications	1
operation	1-4
physical specifications	1
reset	5-7
setup	1-4
Printer Accessories	2
Printer Cleaning	9-2
Printer Options	2
printhead pressure	2-11
Printhead Replacement	9-4
printing	
on-demand	8-2
printing	8-1
Printing	
demand mode	8-1
True Type fonts	8-5
Prompt Set	6-7

R

Reset Defaults	5-7
ribbon	
high energy	4-4
Ribbon	4-3
specifications	2
Ribbon Loading	3-1, 3-2
Ribbon Specification	2
Rotate Image	4-15

S

Scripts	7-1, 7-2
---------------	----------

I-2 Index

deleting	7-5
downloading	7-3
enabling	7-4
Secondary Sign	6-3
Selecting a Function	1-4
Setting	
communication parameters	5-1
Setting Contrast	4-16
Setup Menu	1-4
Skip Index	4-14
Slashed Zero	6-5
Software	10-2
Specifications	1
ribbon	2
supplies	2
Start (XON) Character	5-1
Status Polling	7-6
Stop (XOFF) Character	5-1
Stop Bits	5-1, 5-4
supply	
options	4-2
Supply	
adjusting position	4-9
adjusting print options	4-8
backfeed	4-1
backfeed distance	4-1
black mark	2-1
die cut	2-1
dispense position	4-1
fan fold	2-1, 2-3
feed mode	4-1
margin position	4-1
Options	4-1
position	4-9
print options	4-9, 4-11, 4-12
print position	4-1
ribbon	4-1
roll	2-1
separators	4-1
skip index	4-1
speed	4-1
supply position	4-1
tags	2-1
thermal direct	2-1
thermal transfer	2-1
type	4-1, 4-2
types	2-1
Supply Loading	2-1, 2-2
peel mode	2-6
Ribbon	3-1
Supply Options	4-1
Supply Quality	10-3
Supply Type	4-2
Supply Types	2-1

T

Tag Specifications	2
Tear Bar	2-10
tear edge	2-7
Test	8-2
Test Label	8-2
Toolbox Utilities	1-2
Troubleshooting	10-1, 10-5
True Type fonts	
printing	8-5

U

USB 1-3

V

Values
communication 5-1

default 5-1
Version 10-2

W

wide/narrow knobs 2-11
Word Length 5-1, 5-3



Avery Dennison
170 Monarch Lane
Miamisburg, OH 45342

1-800-543-6650 (In the U.S.A.)
1-800-387-4740 (In Canada)
www.monarch.com